

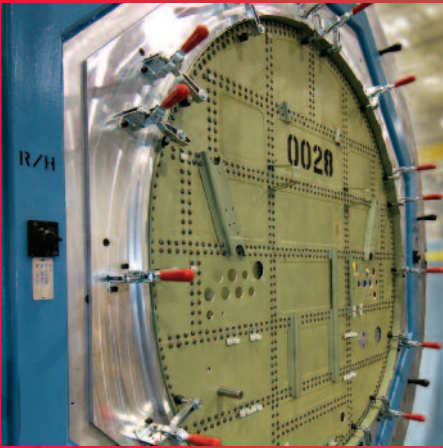

WORKHOLDING & AUTOMATION SOLUTIONS

Aerospace Manufacturing Industry



Custom Products



Vertical Clamps

Horizontal Clamps



Squeeze Action Plier Clamps

Hydraulic Clamps

Straight-Line Action Clamps

Variable Stroke Straight-Line Action Clamps

Latch Clamps

Pneumatic Clamps



End Effector Tooling

Pivot Units

Rotary Actuators

Grippers

Choose partners that can support you on a global scale.

TO REMAIN SUCCESSFUL,
TODAY'S AEROSPACE
MANUFACTURER MUST
BE PREPARED TO OPERATE
IN A GLOBAL MARKET.
DE-STA-CO'S COMMITMENT
TO PROVIDING
INDUSTRY-LEADING
PRODUCTS, SERVICES AND
SUPPORT ENCOMPASSES
THE WHOLE OF THE
WORLD IN WHICH
YOU DO BUSINESS.

As a truly global company, DE-STA-CO understands aerospace manufacturers' need for uniformity across products, service and support, regardless of geographic location. We harness the whole of our resources to ensure worldwide availability of every product we produce. In every country that you conduct business, we provide and support the same standard-setting array of workholding and automation components. Furthermore, the longevity and performance of our products results in the lowest cost of ownership in the industry. Wherever your operations are located, the unmatched quality and value of DE-STA-CO are available.



MORE THAN PRODUCTS. COMPLETE SOLUTIONS.

EXTENSIVE CAD CAPABILITIES



**CAD FILES
AVAILABLE
ONLINE**

To ensure applicability to the broadest possible base of aerospace manufacturers, DE-STA-CO supports a wide variety of CAD programs, ranging from Catia to Unigraphics. All CAD formats are accessible through multiple channels, including our cutting-edge online digital catalog, located at www.destaco.com. This web-based 3D CAD library allows engineers to configure individual 3D models from DE-STA-CO's extensive array of workholding and automation products. The intuitive system is part of DE-STA-CO's commitment to providing the exact CAD information you need, whenever you need it.

WWW.DESTACO.COM

Our global website is a constant resource for our customers worldwide. Designed to be a one-stop engineering resource center, our website was developed by engineers for engineers. Presented in multiple languages, www.destaco.com provides detailed comprehensive product information, data sheets and CAD information twenty-four hours a day, seven days a week.



OUR GLOBAL WEBSITE ALSO OFFERS:

- Access to local sales representatives and dealers
- Sizing software
- Customer service access
- Expert application advice
- Training information
- Downloadable literature

TECHNICAL EXPERTISE, SERVICE AND SUPPORT

At DE-STA-CO, we maintain the highest possible standards of service and support across all of our product offerings. Our employees possess extensive engineering knowledge and receive comprehensive training on all of our products. When you partner with DE-STA-CO, you work with specialists that fully understand your operations, our products and how the two work together to provide you with value. Our customer service staff is available via a toll-free phone line, fax, email and our company website, so that you can reach us through whatever medium is most convenient.



CUSTOMIZED SPECIAL PRODUCTS

EACH OF YOUR APPLICATIONS IS UNIQUE and sometimes it takes more than a standard product to achieve maximum performance in aerospace manufacturing. When such an occasion arises, DE-STA-CO's special engineering services department will work extensively to meet that need by modifying an existing product or creating an entirely new component. Throughout this process, you will work with a highly trained engineer who understands your specific needs. Once a special product is created, it is assigned a part number and entered into our system. This guarantees a quick response to future orders, even if you are the only company in the world that is using that specific product.

••• BEST SOLUTIONS.

••• UNIQUE PART NUMBERS.

••• EXPERT SUPPORT.



High temperature pneumatic clamp for airframe manufacturing.



Pneumatic clamp with manual actuation handle.



Plier clamp modified for mounting plate.



Stainless steel clamp with special hook and control tab.



Latch clamp electroless nickel plating.



Vertical clamp with bar weldment and spring loaded swivel handle.



Carbon fiber end effector tooling.



Tough, urethane coated jaws and spindles on this plier clamp protect critical surfaces.



MANUAL CLAMPS FOR THE AEROSPACE INDUSTRY

VERTICAL CLAMPS

- **Durable construction:** High performance achieved through torsion-protected, hardened bushings, stainless steel rivets and zinc plating.
- **Safe design:** Oil-resistant, ergonomically-shaped DE-STA-CO handle grip increases operational safety.
- **Innovative Design:** Our 2000 Series Vertical Hold Down Clamps offer unparalleled safety and performance.
- Bar openings range from 80° to 140°.

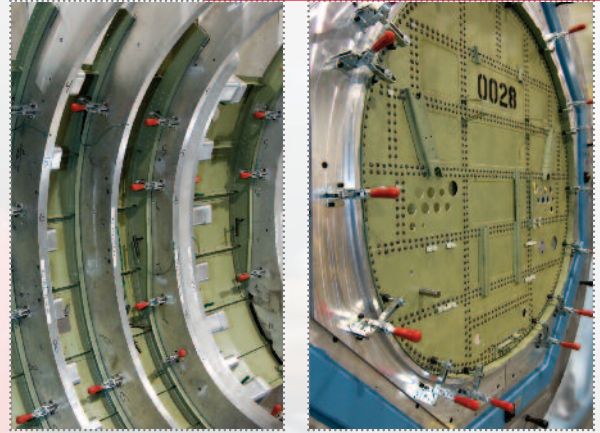

2002-U, 2007-U,
2010-U



2002-UR, 2007-UR,
2010-UR WITH
DE-STA-CO® TOGGLE
LOCK PLUS



2002-U207



2002-UR207
DE-STA-CO® TOGGLE
LOCK PLUS

Model no.	Holding Capacity ↑ [N / lbf.]	Overall Height [mm / in.]	Height Under Bar [mm / in.]	Overall Length [mm / in.]
2002-U	2,800 / 600	120.1 / 4.73	24.3 / 0.95	105.9 / 4.17
2007-U	4,500 / 1,000	183.1 / 7.21	31.6 / 1.25	150.9 / 5.94
2010-U	6,200 / 1,400	228.6 / 9.00	43.3 / 1.70	184.9 / 7.28
2002-UR	2,800 / 600	120.1 / 4.73	24.3 / 0.95	105.9 / 4.17
2007-UR	4,500 / 1,000	183.1 / 7.21	31.6 / 1.25	150.9 / 5.94
2010-UR	6,200 / 1,400	228.6 / 9.00	43.3 / 1.70	184.9 / 7.28
2002-U207	2,800/600	127.3/5.01	31.8/1.25	84.2/3.32

Our manual vertical clamps offer excellent clamping capacity in a compact package.

HORIZONTAL CLAMPS

- **Durable construction:** High performance achieved through stainless steel rivets and zinc plating.
- **Safe design:** Oil resistant, vinyl dipped and ergonomic gripped handles increase operational safety.
- **Innovative Design:** Our new 2000 Series Horizontal Hold Down Clamps offer unparalleled safety and performance.
- Bar openings range from 70° to 90°.

The compact design and excellent clamping force of our horizontal clamps make them ideal for a wide variety of aerospace applications.



225-U, 235-U



225-UR, 235-UR
DE-STA-CO® TOGGLE
LOCK PLUS



2013-U, 2017-U,
2027-U, 2037-U

Model no.	Holding Capacity ↑ [N / lbf.]	Overall Height [mm / in.]	Height Under Bar [mm / in.]	Overall Length [mm / in.]
225-U	2,200/500	46.7/1.84	33.5/1.32	170.2/6.70
235-U	3,200/750	64.8/2.55	44.5/1.75	276.1/10.87
225-UR	2,200/500	48.8/1.92	33.5/1.32	181.4/7.14
235-UR	3,200/750	64.8/2.55	44.5/1.75	276.1/10.87
2013-U	1,310/295	32.3/1.27	19.0/0.75	149.3/5.88
2017-U	2,490/560	176.5/6.95	24.9/0.98	218.9/8.62
2027-U	3,740/840	55.0/2.20	33.5/1.32	251.0/9.88
2037-U	7,470/1,680	60.9/2.75	41.2/1.62	399.1/13.35

MANUAL CLAMPS FOR THE AEROSPACE INDUSTRY

SQUEEZE ACTION PLIER CLAMPS

- **Increased flexibility:** High quality clamping forces are provided where permanent, stationary clamping of workpieces is not possible.
- **Durable construction:** High strength, drop forged alloy steel is used to guarantee maximum performance and reliability.
- **Safe design:** Oil-resistant, vinyl-dipped DE-STA-CO handle grip increases operational safety.
- **Efficient operation:** Some models feature a two-way trigger release for fast and easy opening of clamp.



Our easy-to-use **squeeze action plier clamps** are ideal for holding laminations of materials during riveting or bonding.



431
LIGHTWEIGHT
SLIM DESIGN



462 WITH SPINDLE
AND RELEASE LEVER

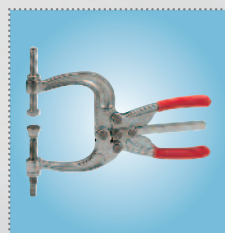

463 WITH SPINDLES
AND RELEASE LEVER

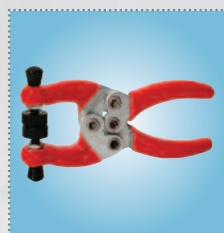

COATED PLIER
TOUGH, URETHANE COATED
JAWS AND SPINDLES ARE
AVAILABLE TO PROTECT
CRITICAL SURFACES.

Model no.	Holding Capacity ↕ [N / lbsf.]	Overall Height [mm / in.]
431	450/100	154.7/6.90
462	3,200/700	215.9/8.50
463	3,200/700	215.9/8.50

PULL ACTION LATCH CLAMPS

- **Innovative design:** Clamps with DE-STA-CO® Toggle Lock Plus feature an integrated locking lever to reduce the potential for unintentional opening. This feature is now available on most Pull Action Latch Clamp models.
- **Durable construction:** High performance achieved through stainless steel rivets and zinc plating. Models with holding capacities ranging from 360 to 7,500 lbf.
- **Safe design:** Oil-resistant, ergonomically-shaped DE-STA-CO handle grip increases operational safety.
- **Complete solution:** Hooks and latch plates included with most models. Custom hooks lengths are available upon request.

Our **latch clamps** are ideal for use in the assembly of wing skins (model 341 shown).



331, 341 HORIZONTAL
TOGGLE CLAMP WITH
U-HOOK



324-R, 334-R, 344-R
VERTICAL U-HOOK
STYLE FEATURING
TOGGLE-LOCK PLUS



330, 351, 371, 381
J-HOOK STYLE

Model no.	Holding Capacity ➔ [N / lbsf.]	Overall Height [mm / in.]	Height Under Bar [mm / in.]	Overall Length [mm / in.]
331/331-R	3,200/700	50.3/1.97	16.8/0.66	153.9/6.06
341/341-R	7,000/2,000	37.4/2.89	23.9/0.94	208.3/8.20
324/324-R	2,220/500	52.7/2.07	38.7/1.53	88.1/3.47
334/334-R	4,490/1,000	64.7/2.55	51.7/2.04	104.6/4.12
344/344-R	8,896/2,000	86.0/3.39	62.4/2.46	146.5/5.77
323/323-R	1,601/360	31.1/1.23	38.7/1.53	108.7/4.27

MANUAL CLAMPS FOR THE AEROSPACE INDUSTRY

STRAIGHT-LINE ACTION CLAMPS

- **Flexible performance:** Models lock over-center in both the extended and retracted positions. Many models available with the DE-STA-CO® Toggle Lock Plus feature that restricts unintentional unlocking.
- **Durable construction:** High performance achieved through stainless steel rivets and zinc plating.
- **Safe design:** Oil-resistant, ergonomically-shaped DE-STA-CO handle grip increases operational safety.
- **Adaptable solution:** Over 20 sizes and styles available to meet any application. Plungers are internally threaded to accept a variety of accessories.

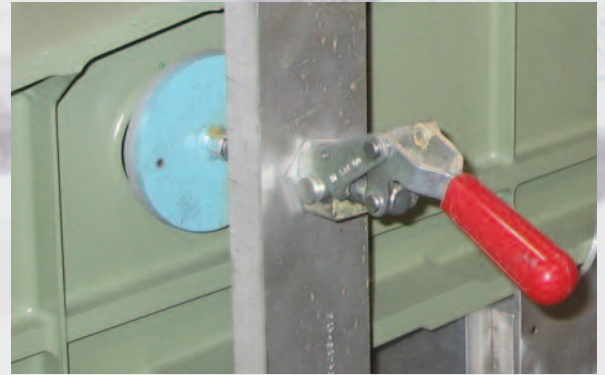

Used in part location, our **straight-line action clamps** improve efficiency in machining and assembly applications (model 624 shown).



6015
COMPACT, ROBUST
STRAIGHT LINE
ACTION CLAMP
FEATURES AN
ALLOY STEEL BASE



603-R
POPULAR SIZE WITH
DE-STA-CO® TOGGLE
LOCK PLUS



604
FEATURES THREADED
BODY NOSE MOUNTING

Model no.	Plunger Travel [mm / in.]	Holding Capacity [N / lbf.]	Overall Height [mm / in.]	Overall Length [mm / in.]
6015	12.7/0.50	2,491/560	40.3/1.59	75.1/2.96
603	24.6/0.97	2,668/600	87.1/3.43	120.1/4.73
604	11.2/0.44	3,560/800	90.4/3.56	152.7/6.01

VARIABLE STROKE STRAIGHT-LINE ACTION CLAMPS

- **Flexible operation:** To meet applications' specific needs, both one-hand and two-hand operation models are available.
- **Multiple mounting options:** Models include options for foot base mounting, flange mounting and through hole mounting.
- **High flexibility:** Variable clamping strokes Accommodate wide variations in workpiece size.

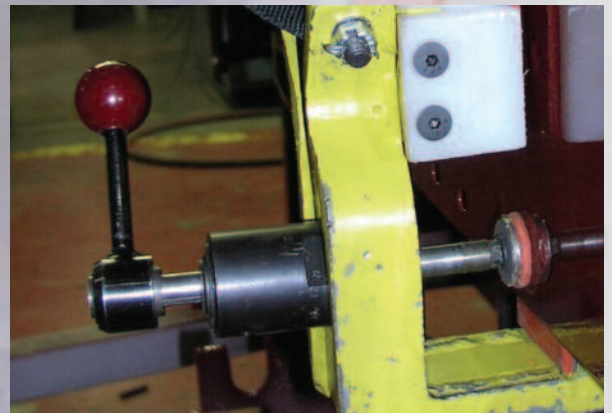

Variable straight-line action clamps can be used to accurately position straight-line motion when parts have variable size (model G-121/45 shown).

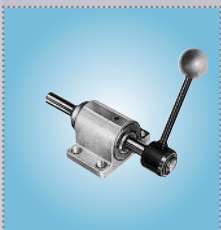

FO SERIES
FLANGED
MOUNT

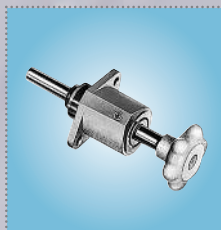

FL SERIES
PILOTED
FRONT FLANGE
MOUNT

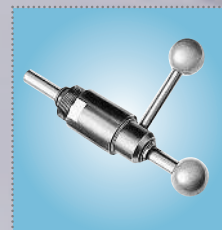

G SERIES
THROUGH
HOLE MOUNT

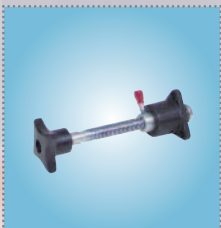

FRF SERIES
FRONT
FLANGE MOUNT



FRL SERIES
FOOT
MOUNT

Model no.	Max. holding capacity [N/lbsf.]	Rapid stroke [mm/in.]	[lbs.]
FO	1,330/300 - 17,790/4,000	40/1.57 - 300/11.8	0.72 - 7.46
FL	1,330/300 - 8,900/2,000	40/1.57 - 300/11.8	0.66 - 3.15
G	1,330/300 - 2,660/600	40/1.57 - 300/11.8	0.66 - 1.31
FRF	24,464/5,500 - 48,930/11,000	60/2.36 - 75/2.97	1.00 - 1.50
FRL	24,464/5,500 - 48,930/11,000	89/3.50 - 104/4.08	1.00 - 1.50

PNEUMATIC & HYDRAULIC CLAMPS FOR THE AEROSPACE INDUSTRY

LIGHT TO HEAVY-DUTY PNEUMATIC CLAMPS

- **Protected design:** Enclosed designs reduce maintenance and increase performance by keeping lubrication in and contaminants out.
- **Flexible performance:** Clamping force can be maintained even when removed from air supply.
- **Extreme capabilities:** High temperature models can withstand continuous exposure to 500° F and short exposure to 700° F.
- **Efficient size:** High clamping forces are provided in a compact, space-efficient design.



NEW



8031 STRAIGHT LINE ACTION CLAMPS



9500 SERIES SWING CLAMPS



82L SERIES LIGHT DUTY CLAMPS



82M SERIES MEDIUM DUTY CLAMPS



1091 MRM HEAVY DUTY CLAMPS

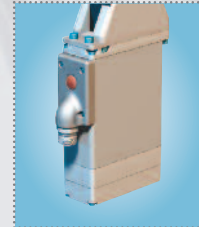

ELECTRIC CLAMPING AND LOCATING PRODUCTS

HYDRAULIC CLAMPS

- **System flexibility:** MRO interchange provides the ability to upgrade and interchange with other brands.
- **Highly adaptable:** Products feature multiple mounting and plumbing options.
- **Durable design:** Advanced seal and wiper technology resists contamination and leaks, while corrosion-resistant metal surfaces increase product life.
- **Improved productivity:** Setup times are significantly reduced through the ability to clamp an entire fixture from one location.



HYDRAULIC SWING/PULL CLAMPS



THREADED BODY CYLINDERS



THRU HOLE RAM



AIR/HYDRAULIC POWER BOOSTERS



END EFFECTOR COMPONENTS FOR THE AEROSPACE INDUSTRY

CUSTOMIZED MATERIAL HANDLING SOLUTIONS

- **Bodybuilder™ Robotic End Effector System** features octagonal booms and clamp mounts designed to be stiff under the twisting, bending moments of a robot's motion. The patented alignment system allows modular components to be replaced individually and easily returned to their original positions.
- **SpiderGrip™ Modular Geometric End Effector System** components are made of high grade aircraft quality aluminum. This tooling system offers high strength-to-weight ratios and maintains dimensional accuracy when replacing individual components.
- **Carbon Fiber World Tool** is a high-strength, lightweight tooling solution designed to dramatically increase overall performance in production while decreasing vibration. Internal steel mounting plates ensure solid connection between boom and automation.
- **Round Tooling Systems** are ideal for small part handling, and unusually shaped objects. This tooling system is constructed of lightweight aluminum and offers a high-volume, low-cost, fully customizable solution.



SpiderGrip is a high tolerance modular system suited to high positional accuracy build of jigs or robot tooling. Above, **SpiderGrip** being used with DE-STA-CO pin (hold-down) clamps to position carbon fiber panels for precision drilling.

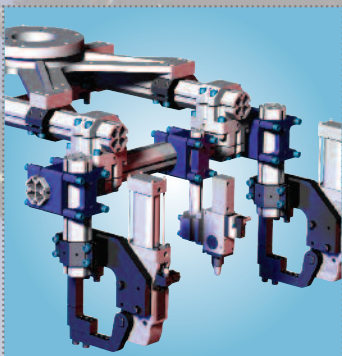

BODYBUILDER™ ROBOTIC END EFFECTORS

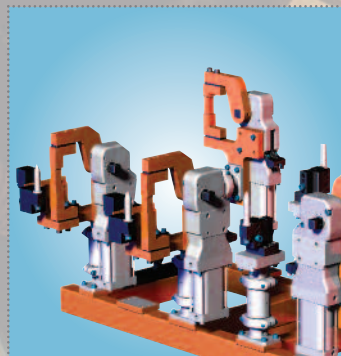

SPIDERGRIP™ MODULAR GEOMETRIC TOOLING



CARBON FIBER WORLD TOOL

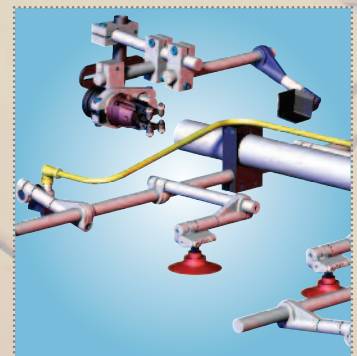

ROUND TOOLING SYSTEMS

END EFFECTOR COMPONENTS FOR THE AEROSPACE INDUSTRY

COMPREHENSIVE STANDARD PRODUCT OFFERING

- **Vacuum Products:** DE-STA-CO offers several families and sizes of vacuum cups for different surfaces, contours and applications. Auto-Release Venturi (ARV) cup mounts provide quick part release while requiring only one air line and one valve.
- **Pneumatic Modular Grippers:** There are two styles of modular grippers, the GR1 Modular Gripper and the GR84 Enclosed Mini Gripper. GR1 has a toggle-locking mechanism while the GR84's locking mechanism is protected from contaminants. They are excellent for gripping and transporting panels within very short cycle times.
- **Manual Tool Changers:** Allows you to quickly switch between various tooling in seconds. Optional integral air ports provide immediate power to your system, eliminates manual re-connection of airlines, and reduces machine downtime.
- **Pneumatic Positioning Slides:** These are offered in three different sizes with four standard strokes for each size. Positioning slides feature sealed, self-lubricating bearing systems which are easy to repair and maintain.



Manual Lift Assist Tool works with existing DE-STA-CO components. One tool can be used for multiple parts and can be transferred from one program to another with minor adjustments.



VACUUM PRODUCTS

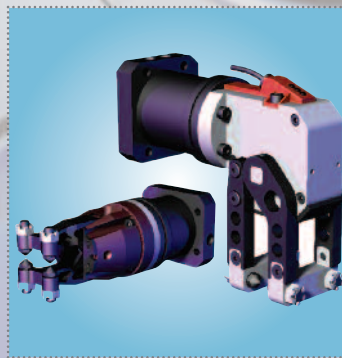

SHEET METAL GRIPPERS

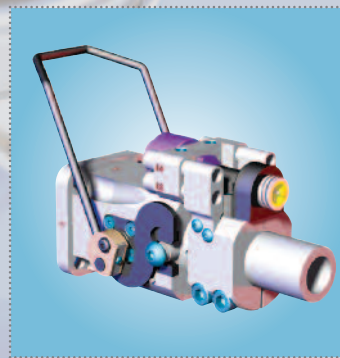

MANUAL TOOL CHANGERS

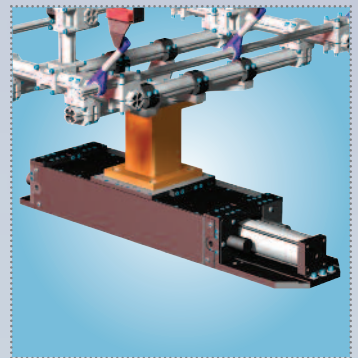

PNEUMATIC POSITIONING SLIDES

OTHER AUTOMATION COMPONENTS FOR THE AEROSPACE INDUSTRY

AUTOMATION GRIPPING AND POSITIONING SOLUTIONS

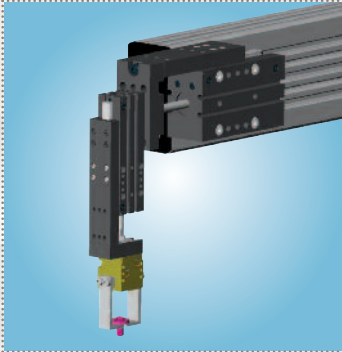

SLIDES

Ideal for the assembly and manufacture of aerospace components, our slides quickly and easily mount together without adaptor plates, and allow you to create an almost unlimited range of multi-axis pick and place devices.

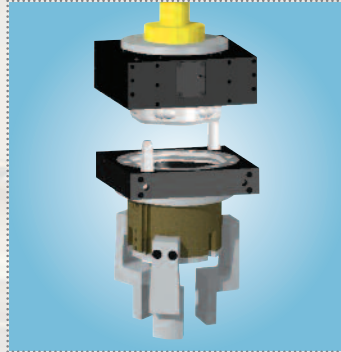

ROBOTIC TOOL CHANGERS

Our robotic tool changers provide a quick and easy way to change end effector tooling to accommodate many different styles of parts on the same robot. These tool changers also offer accurate positional repeatability and withstand moment loads of up to 30,000 in./lbs. – even in harsh environments.

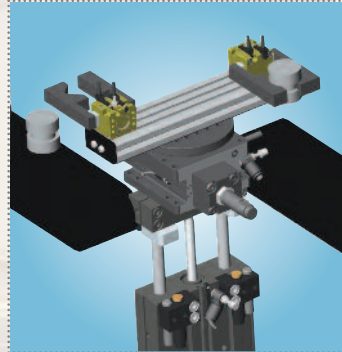

ROTARY ACTUATORS

Zero-backlash, preloaded ball bearings and slip fit dowel pins ensure high precision in our rotary actuators, which are ideal for machine load and unload applications. Our actuators can be supplied with grippers and sensors premounted or with blank mounting surfaces for customer supplied tooling.

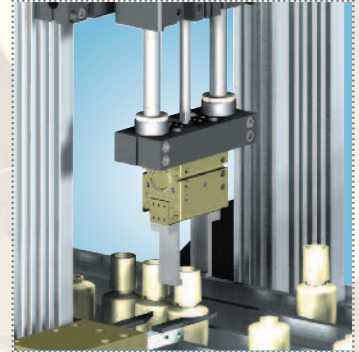

AUTOMATION GRIPPERS

DE-STA-CO offers a comprehensive line of grippers, many of which support long finger lengths and excel in the handling and transfer of large and heavy parts. Our patented DIRECTCONNECT™ technology eliminates the need for adaptor plates.

PRECISION INDEXING PRODUCTS AND MODULAR CONVEYOR SYSTEMS

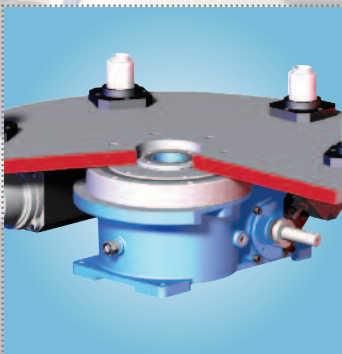

RDM SERIES INDEX DRIVES

Ideal for rotary dial applications with features including:

- Low Profile
- Large center thru hole
- Large output mounting surface
- Complete, motorized drive package and optional overload clutch

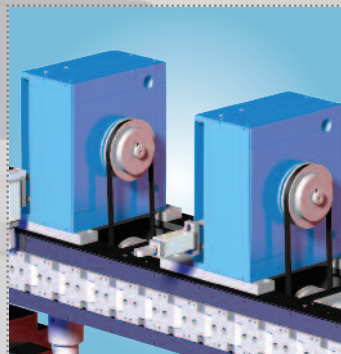

LPP LINEAR PARTS HANDLER

combined with other DE-STA-CO products, offer a low maintenance, cost-effective solution for a complete parts handling package.

- Low-cost operation
- Reliable CAMCO mechanical cam design
- Lubed for Life



IM-PAC AC DRIVES

Optimized for cam-operated indexing applications.

- Easy setup with factory preset parameters
- Simple connections: easy-access terminals with clear markings
- Up to 60 cycles per minute using high-performance 1/3 to 2 hp AC motors



MODULAR CONVEYOR SYSTEMS

Custom designed to fit the customer needs, using standard options (drives, belts, and materials), controllers, and accessories. Specialty conveyors (vacuum, magnetic) and tray handlers are also available.



A DOVER COMPANY

PRECISELY POSITIONING OUR CUSTOMERS FOR PRODUCTIVITY.

Workholding

- Widest variety of workholding products
- High durability and reliability
- Flexible solutions for all applications
- Custom products for unique requirements

Automation

- Broad range of engineered automation products
- Complementary products for modular integration
- Unmatched accuracy, reliability and performance
- Unparalleled global sales, service and engineering support

DE-STA-CO GLOBAL LOCATIONS

NORTH AMERICA

DE-STA-CO Headquarters
 Auburn Hills, Michigan
 Tel: 1.248.836.6700
 Toll Free: 1.888.DESTACO
 Marketing: marketing@destaco.com
 Customer Service: customerservice@destaco.com

Charlevoix, Michigan
 Tel: 1.888.DESTACO
 Customer Service: customerservice@destaco.com

Wheeling, Illinois
 Tel: 1.800.645.5207
 Customer Service: camco@destaco.com

Red Wing, MN (Central Research Laboratories)
 Tel: 651.385.2142
 Customer Service: sales@centres.com

SOUTH AMERICA

Brazil
 Tel: 0800-124070
 Customer Service: samerica@destaco.com

ASIA

Thailand
 Tel: +66-2-326-0812
 Customer Service: info@destaco.com

China
 Tel: +86-21-6081-2888
 Customer Service: china@destaco.com

India
 Tel: +91-80-41123421-426
 Customer Service: india@destaco.com

EUROPE

Germany
 Tel: +49-6171-705-0
 Customer Service: europe@destaco.com

France
 Tel: +33-1-3996-5000
 Customer Service: france@destaco.com

UK
 Tel: +44-1902-797980
 Customer Service: uk@destaco.com

Spain
 Tel: +34-936361680
 Customer Service: spain@destaco.com

Netherlands
 Tel: +31-297285332
 Customer Service: benelux@destaco.com



A DOVER COMPANY

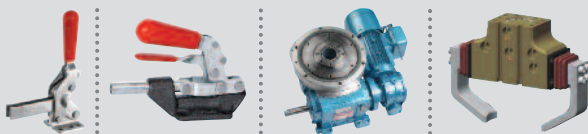

Precisely positioning our customers for productivity.

1025 Doris Road
 Auburn Hills, MI 48326
 Fax: (248) 836-6740
 Technical Support E-mail:
tech-automotive@destaco.com
www.destaco.com