

A single Carver Model T500-1 moving head, and two T500-2, fixed head Edge Grip clamps hold a part for milling.

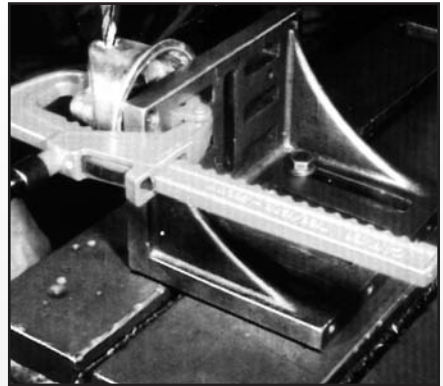

Carver Model T285-18 "C" style clamp used in a drilling operation.



Two low-profile T500 Carver Edge Grip clamps apply both horizontal and vertical clamping force to secure parts for a milling operation. This double action is beyond the capabilities of machine vises.

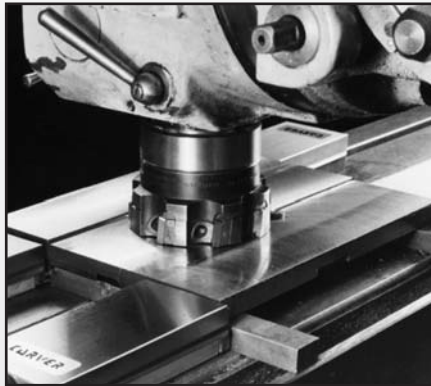

Two Carver Model T614-0 clamps secure a part fixture during a drilling application.

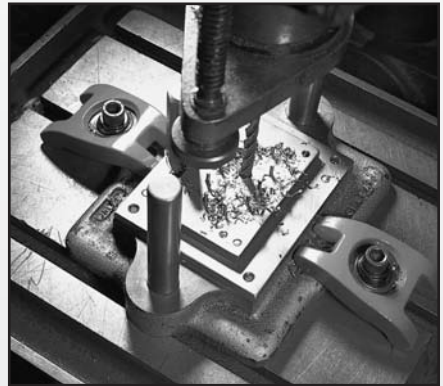

A circular part is held for a slot milling operation using Carver Model T550-2 heavy-duty Edge Grip clamps. The T550-2 clamps swivel a full 360° for infinite angular alignment.

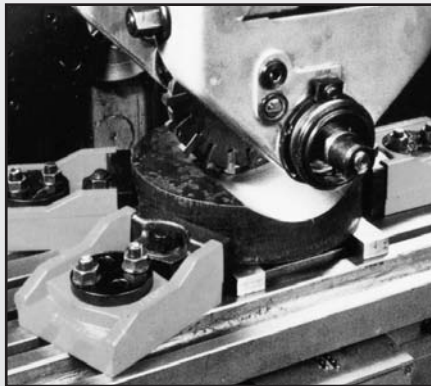

Two versatile Carver Bar Style clamps used in a welding application. The clamps are supplied with two reversible jaws for either clamping or spreading.



Carver heavy-duty Edge Grip Models T550-1 and T550-2 used in a milling application.

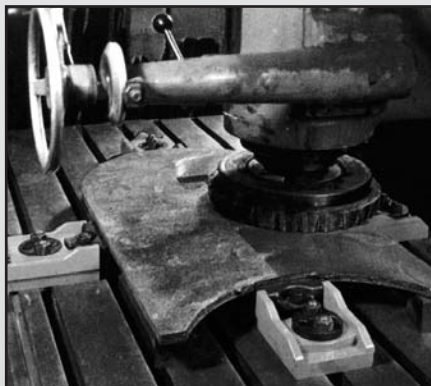

Two Carver Model T614-1 Buttress Style clamps provide exceptional stability to the workpiece in this milling process.



Product range

| Bar-Style | | | |
|---|-----------|------------------------------|------|
| | Model no. | Holding Capacity max. [lbs.] | Page |
|  | T186-24 | 2,500 | 10.4 |
| | T186-36 | 2,500 | |
| | T186-60 | 2,500 | |
| | T186-84 | 2,500 | |
| | T186-96 | 2,500 | |
|  | T321-24 | 1,500 | |
| | T321-36 | 1,500 | |
| | T321-60 | 1,500 | |
| | T321-84 | 1,500 | |
| | T321-96 | 1,500 | |
|  | T290-36 | 4,000 | |
| | T290-60 | 4,000 | |
| | T290-84 | 4,000 | |
| | T290-48 | 4,000 | |
|  | T285-36 | 2,000 | |
| | T285-60 | 2,000 | |
| | T285-84 | 2,000 | |
| | T285-48 | 2,000 | |
|  | T257-84 | 6,000 | |
| | T257-108 | 6,000 | |

| C-Style | | | |
|---|-----------|------------------------------|------|
| | Model no. | Holding Capacity max. [lbs.] | Page |
|  | T186-6 | 2,500 | 10.6 |
| | T186-12 | | |
| | T186-20 | | |
| | T186-30 | | |
| | | | |
|  | T321-10 | 1,250 | |
| | | | |
|  | T290-9 | 4,000 | |
| | T290-18 | | |
| | T290-40 | | |
|  | T285-9 | 2,000 | |
| | T285-18 | | |
| | T285-40 | | |
| | | | |
|  | T257-6 | 6,000 | |
| | T257-12 | | |
| | T257-18 | | |
| | T257-24 | | |
| | T257-36 | | |
| | T257-54 | | |

Typical Applications

Bar Clamps

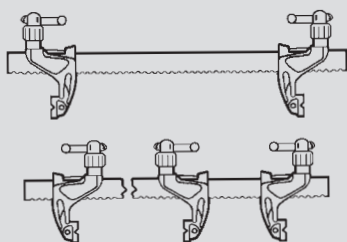

"C" Clamps

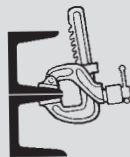



No obstruction from long screw.
Ideal for structural steel fabrication.



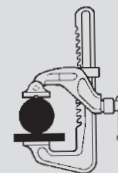

Unaffected by weld spatter.
Screw is shielded and out of work area.



Holds rounds to flats.
Limited movement of moveable jaw pad and grooved face ensure positive grip on round objects.

| Buttress Style | | | |
|---|-----------|------------------------------|------|
| | Model no. | Holding Capacity max. [lbs.] | Page |
|  | T614-0 | 2,875 | 10.8 |
|  | T614-1 | 13,750 | |
|  | T614-2 | 17,600 | |

| Edge Grip Style | | | |
|--|-----------|------------------------------------|-------|
| | Model no. | Holding Capacity max. [lbs.] | Page |
|  | T500 | 1,980 Horizontal 1,980 Vertical | 10.10 |
|  | T550 | 9,900 Horizontal 3,960 Vertical | |

Typical Applications

Buttress Clamps

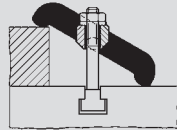

T-Slot Clamps

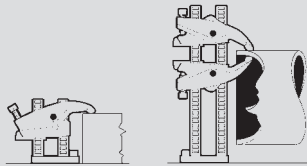



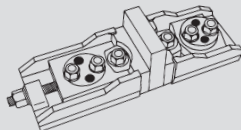

Ideal for use as manual die clamps. Eliminates the need for step blocks or riser blocks.

Edge Grip Clamps



T-Slot Style

| | Model no. | Holding Capacity max. [lbs.] | Page |
|--|--|------------------------------|-------|
|  | T400-4 T400-6 T400-8 | 5,000 | 10.12 |
|  | T600-4 T600-6 T600-8 | 3,500 | |
|  | T402-6 T402-12 T402-18 T402-24 | 8,000 | |
|  | T602-6 T602-12 T602-18 T602-24 T602-30 | 5,500 | |

Bar-Style

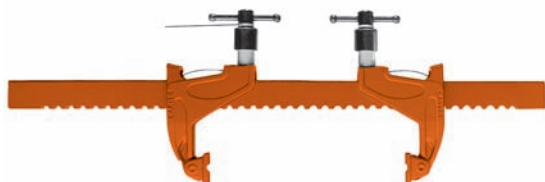

These rugged clamps, made from high-tensile, heat-treated steel, are designed for all types of applications requiring large holding capacities from 1,250 to 6,000 lbs. The clamps are highly versatile. For example, jaws can be reversed to provide spreading action, or several jaws can be used on a single bar both for fixturing and positive component location and clamping.

Available models include T321 Standard-Duty Deep Throat, T285 Medium-Duty Deep Throat, T186 Standard-Duty, T290 Medium-Duty and T257 Heavy-Duty. In addition, standard and medium-duty connectors are available to couple like bars together for increased clamping reaches.

Fits 2 bars

| Model no. | For Bar Clamps Model no. | Weight [lbs.] |
|-----------|--------------------------|---------------|
| T186-13 ▲ | T186-.. and T321-.. | 1.54 |
| T290-13 | T285-.. and T290-.. | 2.87 |

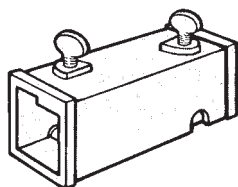

Connector

| Holding Capacity [lbs.] | Throat Depth B ₁ | Width Opening S | | Width Opening S ₁ | | Model no. | Clamping Screw Ø | Weight [lbs.] | Consisting of: | |
|-------------------------|-----------------------------|-----------------|-----|------------------------------|-------|------------|------------------|---------------|----------------|-------|
| | | min | max | min | max | | | | 1 x | 2 x |
| 2,500 lbs. | 2.38 | 8.50 | 24 | 2.95 | 26.77 | T186-24 | M12 | 7.50 | 186-24-1 | 186-2 |
| | | 8.50 | 36 | 2.95 | 38.98 | T186-36 | | 9.50 | 186-36-1 | 186-2 |
| | | 8.50 | 60 | 2.95 | – | T186-60 ▲ | | 13.50 | 186-60-1 | 186-2 |
| | | 8.50 | 84 | 2.95 | – | T186-84 ▲ | | 17.50 | 186-84-1 | 186-2 |
| | | 8.50 | 96 | 2.95 | – | T186-96 ▲ | | 19.50 | 186-96-1 | 186-2 |
| 1,250 lbs. | 4.7 | 5.50 | 24 | 3.15 | 27.17 | T321-24 | M12 | 7.00 | 186-24-1 | 321-2 |
| | | 5.50 | 36 | 3.15 | 39.37 | T321-36 | | 9.00 | 186-36-1 | 321-2 |
| | | 5.50 | 60 | 3.15 | 62.99 | T321-60 | | 13.00 | 186-60-1 | 321-2 |
| | | 5.50 | 84 | 3.15 | – | T321-84 ▲ | | 17.00 | 186-84-1 | 321-2 |
| | | 5.50 | 96 | 3.15 | – | T321-96 ▲ | | 19.00 | 186-96-1 | 321-2 |
| 4,000 lbs. | 3.5 | 10.00 | 36 | 4.72 | 39.57 | T290-36 | M16 | 20.50 | 290-36-1 | 290-2 |
| | | 10.00 | 48 | 4.72 | – | T290-48 | | 24.50 | 290-48-1 | 290-2 |
| | | 10.00 | 60 | 4.72 | 63.78 | T290-60 ▲ | | 28.50 | 290-60-1 | 290-2 |
| | | 10.00 | 84 | 4.72 | 87.40 | T290-84 ▲ | | 36.50 | 290-84-1 | 290-2 |
| 2,000 lbs. | 8.0 | 6.00 | 36 | 4.72 | 42.72 | T285-36 | M16 | 24.50 | 290-36-1 | 285-2 |
| | | 6.00 | 48 | 4.72 | – | T285-48 | | 28.50 | 290-48-1 | 285-2 |
| | | 6.00 | 60 | 4.72 | 66.93 | T285-60 ▲ | | 32.50 | 290-60-1 | 285-2 |
| | | 6.00 | 84 | 4.72 | 90.55 | T285-84 ▲ | | 40.50 | 290-84-1 | 285-2 |
| 6,000 lbs. | 4.5 | 12.00 | 84 | 5.90 | 86.61 | T257-84 ▲ | M20 | 61.00 | 257-84-1 | 257-2 |
| | | 12.00 | 108 | 5.90 | – | T257-108 ▲ | | 71.00 | 257-108-1 | 257-2 |

▲ Available upon request

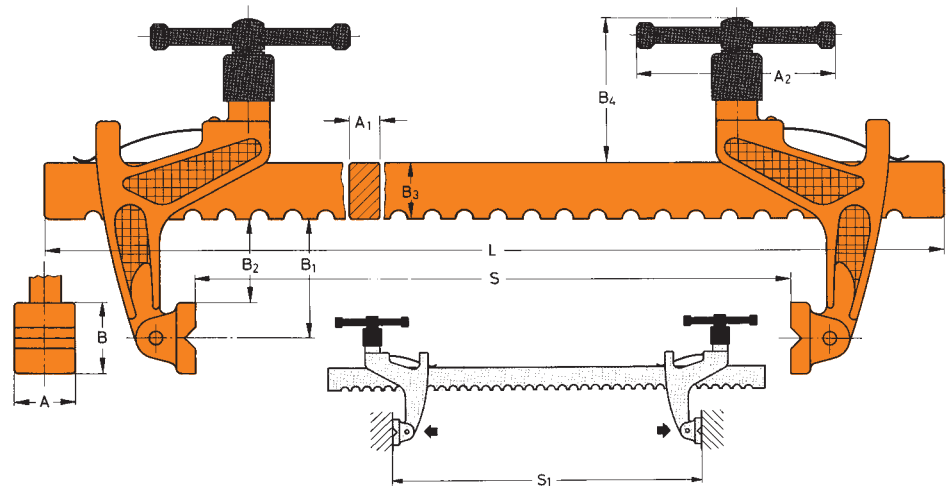

| Model no. | A | A ₁ | A ₂ | B | B ₂ | B ₃ | B ₄ | L |
|------------|------|----------------|----------------|------|----------------|----------------|----------------|--------|
| T186-24 | 0.98 | 0.47 | 2.99 | 1.26 | 1.73 | 1.18 | 2.99 | 27.75 |
| T186-36 | 0.98 | 0.47 | 2.99 | 1.26 | 1.73 | 1.18 | 2.99 | 39.75 |
| T186-60 ▲ | 0.98 | 0.47 | 2.99 | 1.26 | 1.73 | 1.18 | 2.99 | 63.95 |
| T186-84 ▲ | 0.98 | 0.47 | 2.99 | 1.26 | 1.73 | 1.18 | 2.99 | 87.75 |
| T186-96 ▲ | 0.98 | 0.47 | 2.99 | 1.26 | 1.73 | 1.18 | 2.99 | 99.75 |
| T321-24 | 0.98 | 0.47 | 2.99 | 1.26 | 4.09 | 1.18 | 2.99 | 27.75 |
| T321-36 | 0.98 | 0.47 | 2.99 | 1.26 | 4.09 | 1.18 | 2.99 | 39.75 |
| T321-60 | 0.98 | 0.47 | 2.99 | 1.26 | 4.09 | 1.18 | 2.99 | 63.95 |
| T321-84 ▲ | 0.98 | 0.47 | 2.99 | 1.26 | 4.09 | 1.18 | 2.99 | 87.75 |
| T321-96 ▲ | 0.98 | 0.47 | 2.99 | 1.26 | 4.09 | 1.18 | 2.99 | 99.75 |
| T290-36 | 1.50 | 0.79 | 5.51 | 2.00 | 2.56 | 1.57 | 4.13 | 39.75 |
| T290-48 | 1.50 | 0.79 | 5.51 | 2.00 | 2.56 | 1.57 | 4.13 | 51.50 |
| T290-60 ▲ | 1.50 | 0.79 | 5.51 | 2.00 | 2.56 | 1.57 | 4.13 | 63.38 |
| T290-84 ▲ | 1.50 | 0.79 | 5.51 | 2.00 | 2.56 | 1.57 | 4.13 | 87.50 |
| T285-36 | 1.50 | 0.79 | 5.51 | 2.00 | 7.09 | 1.57 | 4.13 | 39.75 |
| T285-48 | 1.50 | 0.79 | 5.51 | 2.00 | 7.09 | 1.57 | 4.13 | 51.50 |
| T285-60 ▲ | 1.50 | 0.79 | 5.51 | 2.00 | 7.09 | 1.57 | 4.13 | 63.38 |
| T285-84 ▲ | 1.50 | 0.79 | 5.51 | 2.00 | 7.09 | 1.57 | 4.13 | 87.50 |
| T257-84 ▲ | 2.00 | 0.87 | 7.36 | 2.50 | 3.27 | 2.05 | 5.00 | 90.38 |
| T257-108 ▲ | 2.00 | 0.87 | 7.36 | 2.50 | 3.27 | 2.05 | 5.00 | 114.38 |

▲ Available upon request

C-Style





Operation

Operation is very simple. The operator slides the spring loaded moveable jaw toward the workpiece to the nearest notch where it locks into the detent. Hand tightening the screw advances the clamp jaw. The jaw advances the tilting pad directly into contact

with the workpiece – there is no rotating to twist the work or the clamp out of position.

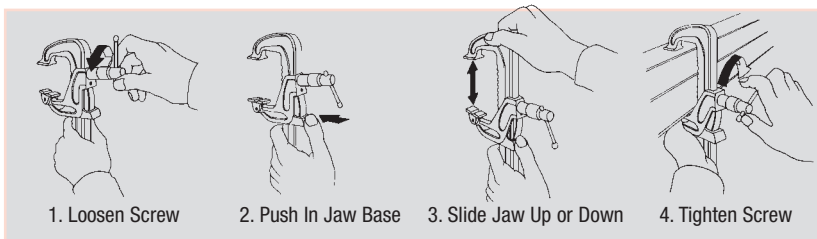
An unusual and very useful feature of these clamps is the ability to use the clamp for spreading or locating as well as squeezing.

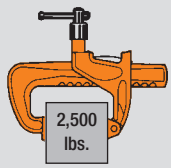
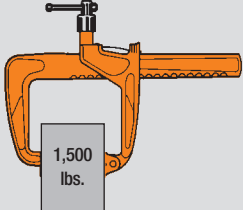
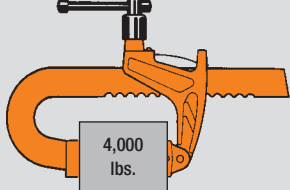
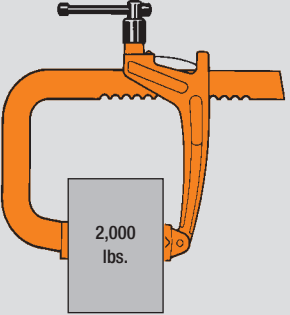
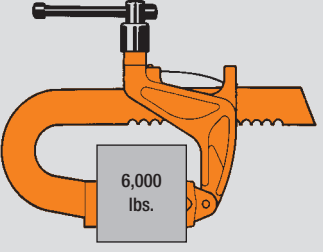

| Holding Capacity [lbs.] | Throat Depth B ₁ | Width Opening S | Model no. | Clamping Screw Ø | Weight [lbs.] | Consisting of: | |
|---|-----------------------------|-----------------|-----------|------------------|---------------|---|---|
| | | | | | | 1 x  | 2 x  |
|  2,500 lbs. | 2.38 | 0-6 | T186-6 | M12 | 2.75 | 186-6-1 | 186-2 |
| | | 0-12 | T186-12 | | 3.75 | 186-12-1 | 186-2 |
| | | 0-20 | T186-20 ▲ | | 5.51 | 186-20-1 | 186-2 |
| | | 0-30 | T186-30 ▲ | | 7.05 | 186-30-1 | 186-2 |
|  1,500 lbs. | 4.75 | 0-10 | T321-10 | M12 | 4.00 | 321-10-1 | 321-2 |
|  4,000 lbs. | 3.50 | 0-9 | T290-9 | M16 | 10.00 | 290-9-1 | 290-2 |
| | | 0-18 | T290-18 | | 13.50 | 290-18-1 | 290-2 |
| | | 0-40 | T290-40 ▲ | | 23.15 | 290-40-1 | 290-2 |
|  2,000 lbs. | 8.00 | 0-9 | T285-9 | M16 | 12.00 | 285-9-1 | 285-2 |
| | | 0-18 | T285-18 | | 13.50 | 285-18-1 | 285-2 |
| | | 0-40 | T285-40 ▲ | | 25.35 | 285-40-1 | 285-2 |
|  6,000 lbs. | 4.50 | 0-6 | T257-6 ▲ | M20 | 20.00 | 257-6-1 | 257-2 |
| | | 0-12 | T257-12 ▲ | | 22.50 | 257-12-1 | 257-2 |
| | | 0-18 | T257-18 ▲ | | 25.00 | 257-18-1 | 257-2 |
| | | 0-24 | T257-24 | | 27.50 | 257-24-1 | 257-2 |
| | | 0-36 | T257-36 | | 32.50 | 257-36-1 | 257-2 |
| | | 0-54 | T257-54 ▲ | | 41.00 | 257-54-1 | 257-2 |

▲ Available upon request

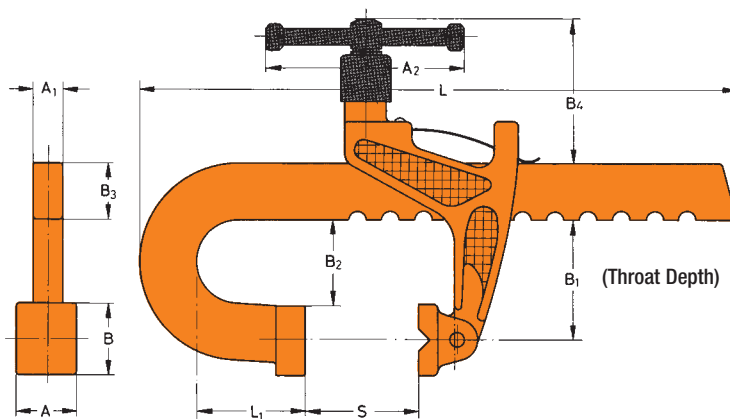

| Model no. | A | A ₁ | A ₂ | B | B ₂ | B ₃ | B ₄ | L | L ₁ |
|-----------|------|----------------|----------------|------|----------------|----------------|----------------|-------|----------------|
| T186-6 | 0.98 | 0.51 | 3.00 | 1.25 | 1.69 | 1.30 | 3.00 | 9.63 | 0.88 |
| T186-12 | 0.98 | 0.51 | 3.00 | 1.25 | 1.69 | 1.30 | 3.00 | 15.50 | 0.88 |
| T186-20 ▲ | 0.98 | 0.47 | 3.00 | 1.38 | 1.69 | 1.18 | 3.00 | 27.36 | 3.15 |
| T186-30 ▲ | 0.98 | 0.47 | 3.00 | 1.38 | 1.69 | 1.18 | 3.00 | 34.45 | 1.18 |
| T321-10 | 0.98 | 0.51 | 3.00 | 1.25 | 4.02 | 1.32 | 3.00 | 14.25 | 1.00 |
| T290-9 | 1.57 | 0.79 | 5.51 | 2.36 | 2.56 | 1.57 | 4.13 | 16.50 | 2.75 |
| T290-18 | 1.57 | 0.79 | 5.51 | 2.36 | 2.56 | 1.57 | 4.13 | 25.50 | 2.75 |
| T290-40 ▲ | 1.57 | 0.79 | 5.51 | 2.36 | 2.56 | 1.57 | 4.13 | 47.44 | 2.75 |
| T285-9 | 1.57 | 0.79 | 5.51 | 2.36 | 7.09 | 1.57 | 4.13 | 16.50 | 2.75 |
| T285-18 | 1.57 | 0.79 | 5.51 | 2.36 | 7.09 | 1.57 | 4.13 | 25.50 | 2.75 |
| T285-40 ▲ | 1.57 | 0.79 | 5.51 | 2.36 | 7.09 | 1.57 | 4.13 | 47.44 | 2.75 |
| T257-6 ▲ | 2.00 | 0.87 | 7.36 | 2.36 | 3.35 | 2.00 | 5.00 | 13.38 | 3.75 |
| T257-12 ▲ | 2.00 | 0.87 | 7.36 | 2.36 | 3.35 | 2.00 | 5.00 | 21.50 | 3.75 |
| T257-18 ▲ | 2.00 | 0.87 | 7.36 | 2.36 | 3.35 | 2.00 | 5.00 | 27.38 | 3.75 |
| T257-24 | 2.00 | 0.87 | 7.36 | 2.36 | 3.35 | 2.00 | 5.00 | 33.50 | 3.75 |
| T257-36 | 2.00 | 0.87 | 7.36 | 2.36 | 3.35 | 2.00 | 5.00 | 45.50 | 3.75 |
| T257-54 ▲ | 2.00 | 0.87 | 7.36 | 2.36 | 3.35 | 2.00 | 5.00 | 63.50 | 3.75 |

▲ Available upon request

Buttress Style

These workholding clamps are designed for use on thin or low-profile workpieces replacing ordinary strap clamps. They feature a self-aligning swiveling pivot which allows the tightening bolt to always remain vertical, preventing any side forces.

The two-point contact offered by Models T614-0 and T614-1 also provides greater stability to the workpiece. Ideally suited for manual die clamping. Eliminates the need for step blocks or riser blocks.

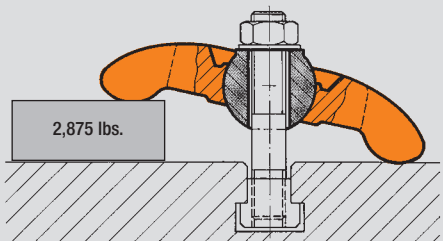
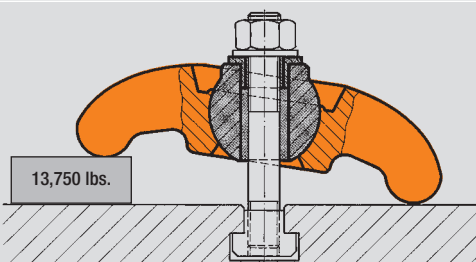
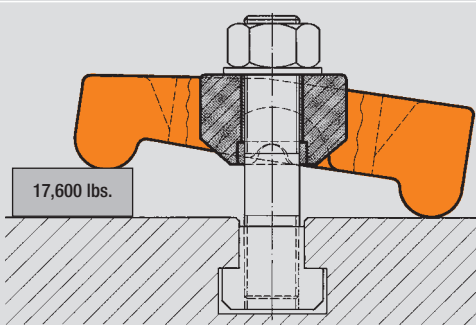

| Holding Capacity [lbs.] | Working Height Range | For screw diameter | Model no. | Weight [lbs.] |
|--|----------------------|---------------------|-----------|---------------|
|  <p>2,875 lbs.</p> | 0-1.75" | 1/2" | T614-0 | 1.5 |
|  <p>13,750 lbs.</p> | 0-2.25" | 5/8" and 3/4" | T614-1 | 5.8 |
|  <p>17,600 lbs.</p> | 0-3.00" | 1" | T614-2 | 9.5 |

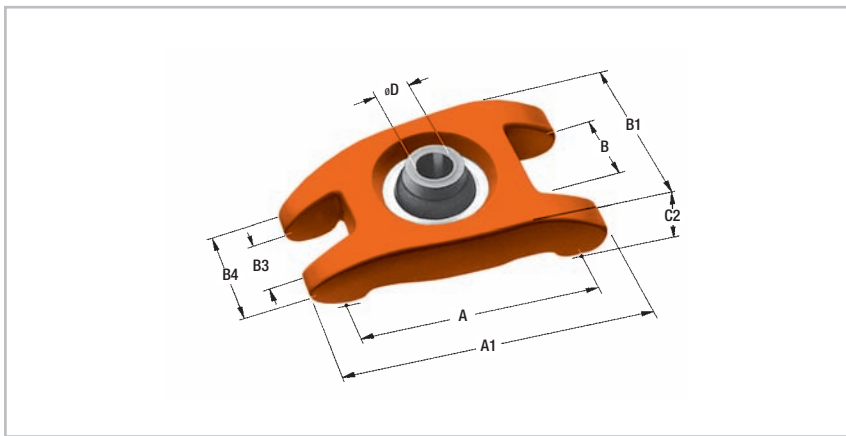

Holding capacity 2,875 lbs.
Clamping height 1.75" max.
Model no. T614-0

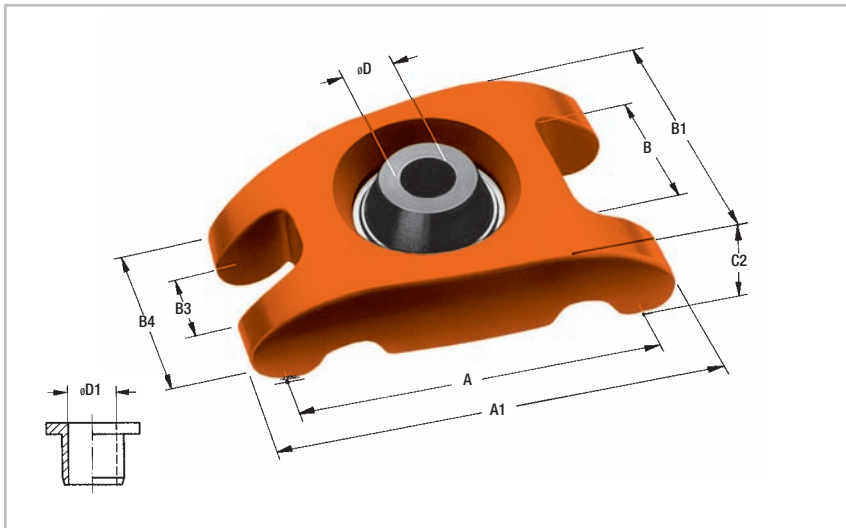
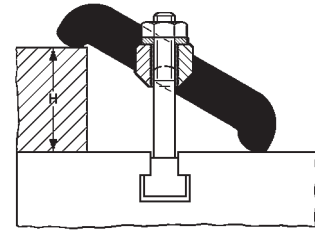

Holding capacity 13,750 lbs.
Clamping height 2.25" max.
Model no. T614-1

Delivery includes reducing bush with inner diameter 0.67".

Reducer bushing is standard equipment

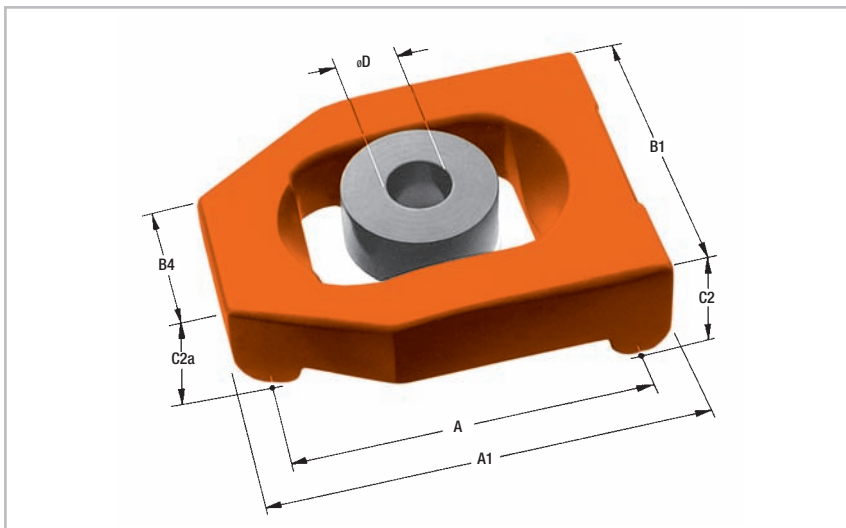
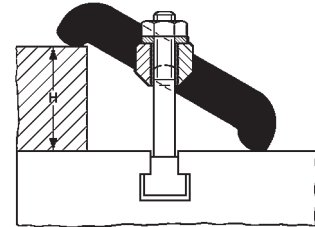

Holding capacity 17,600 lbs.
Clamping height 3.00" max.
Model no. T614-2

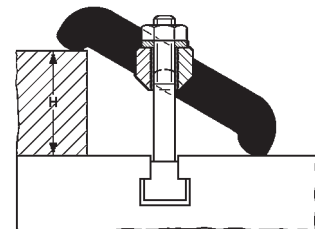

| Model no. | A | A1 | B | B1 | B3 | B4 | C2 | C2a | øD | øD1 |
|-----------|------|------|------|------|------|------|------|------|------|------|
| T614-0 | 3.54 | 4.34 | 1.41 | 2.56 | 0.78 | 1.56 | 0.78 | – | 0.51 | – |
| T614-1 | 5.28 | 6.31 | 2.38 | 3.94 | 1.13 | 2.69 | 1.81 | – | 0.83 | 0.67 |
| T614-2 | 5.83 | 6.69 | – | 5.13 | – | 2.56 | 1.97 | 1.57 | 1.02 | – |

Edge Grip Style

These low-profile clamps apply both horizontal and vertical clamping force against the workpiece to pull it down onto the work table as well as clamp it in position. They are designed to be used with T-Slot tables (or bolted to a plate) and allow maximum cutter access to the workpiece's surface. Edge Grip clamps are excellent for milling, planing, grinding and general surfacing operations which are beyond the capabilities of machine vises.

Because the Edge Grip clamp set consists of two separate pieces – both locked to the T-Slot table – any length part (within the dimensions of the table) can be clamped.

The heavy-duty model also gives the additional advantage of swiveling through a full 360° for infinite angular alignment and gives a choice of two mounting hole sizes.

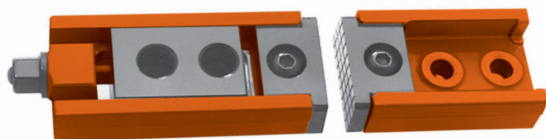

Model no. T500 ▲

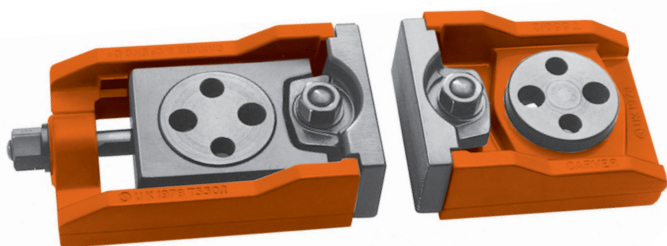

Model no. T550 ▲

| Clamping force | | The total set consists | For screw diameter | Model no. | Weight [lbs.] |
|----------------|------------|---|--------------------|-----------|---------------|
| Horizontal | Vertical | | | | |
| 1,980 lbs. | 1,980 lbs. | 1 moving head with swarf cover (T500-1) (T500-2) 1 fixed head with swarf cover 4 T-slot nuts 14 (M12) 4 button head socket screws (M12 x 35) 2 hex keys | 1/2" | T500 | 8.38 |
| 9,900 lbs. | 3,960 lbs. | 1 Moving head (T550-1) 1 Fixed head (T550-1) | 5/8" and 3/4" | T550 | 52.91 |

▲ Available upon request

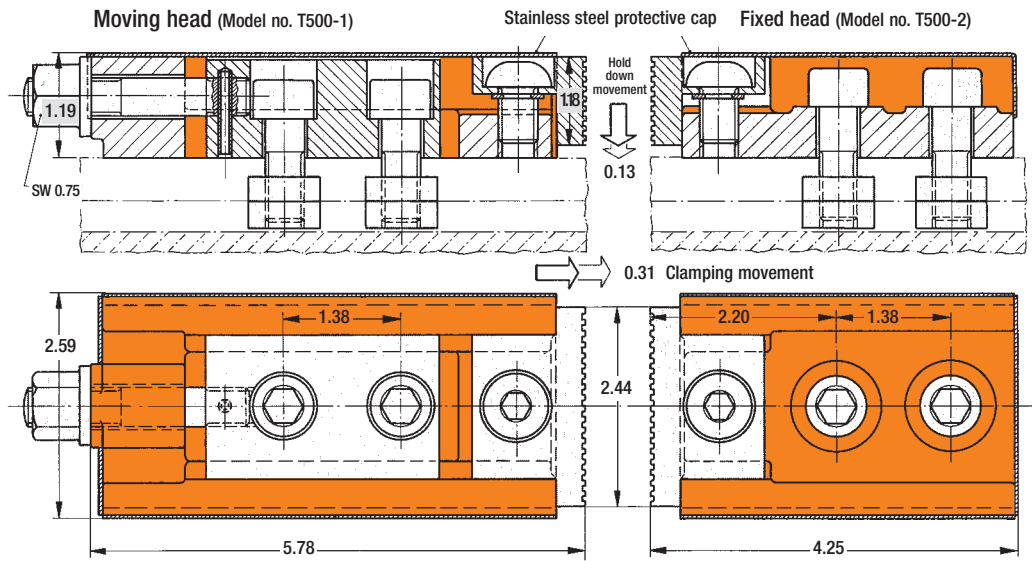

Operating instruction

1. Place clamps against workpiece and tighten cap screws on fixed head
2. Tighten anchor cap screws on moving head
3. Apply pressure with rear-nut slightly
4. Tighten down jaw screws on fixed and moving heads
5. Apply pressure with rear-nut

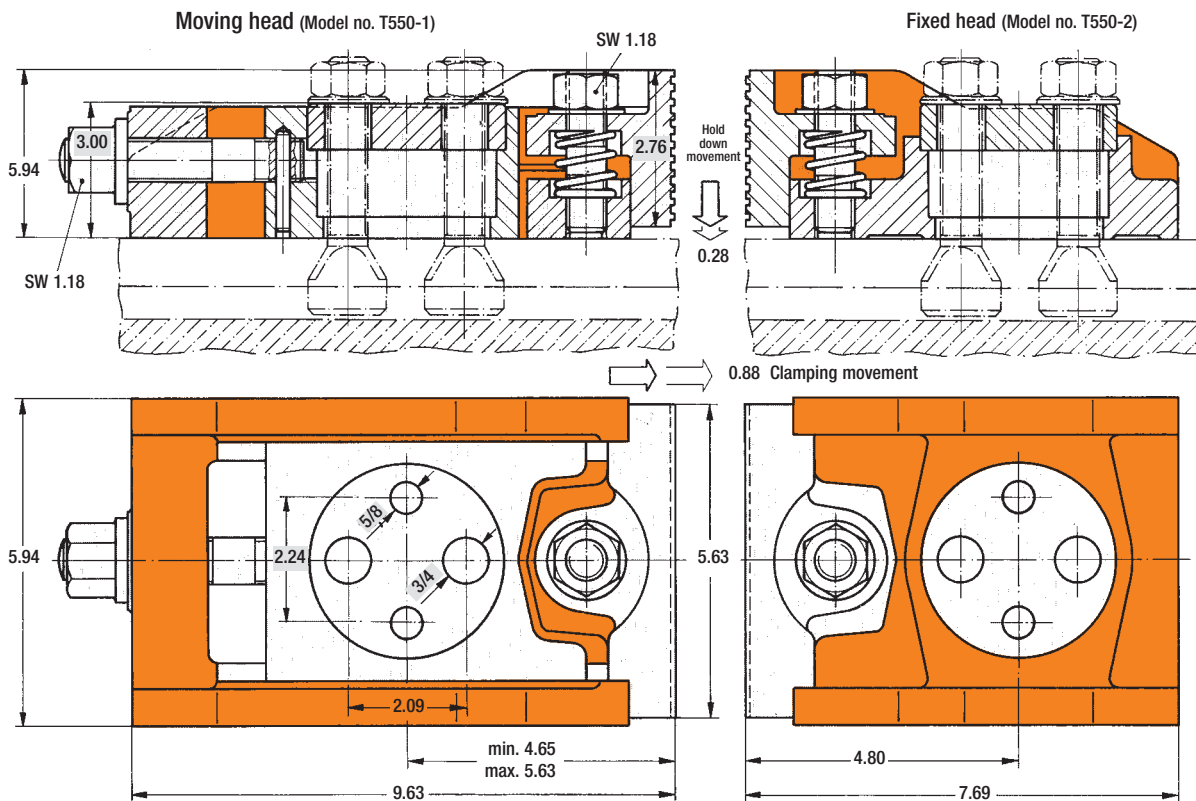
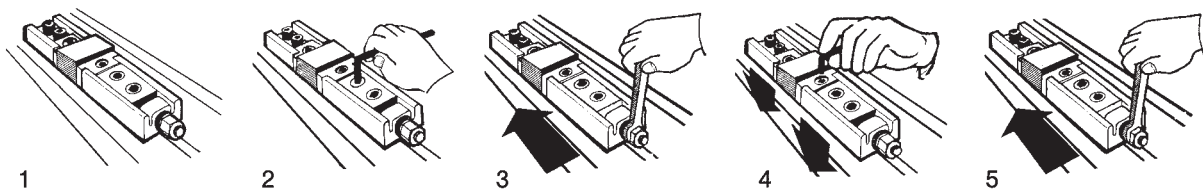

T-Slot Style

These patented clamps provide rapid height adjustment and positive holding. They are designed with a single-unit clamp head and base. The DE-STA-CO CARVER T-Slot Clamp is one single assembly – there are no loose parts.



When setting up, the safety lock on the back is released and the clamp lifted on the base to the desired height. When the clamp screw is turned, 100% of the force is transmitted to the work-piece. Backing off the clamp adjusting screw and releasing the safety lock and lifting the clamp head makes for rapid job changeover.

Formula to Calculate Clamping Force

$$\text{Force (lbf.)} = \frac{\text{Torque (in. lbf.)}}{\text{Thread Size (in.)} \times 0.12}$$

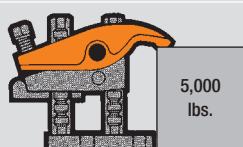
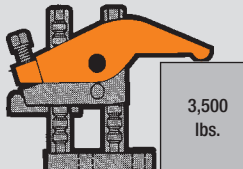
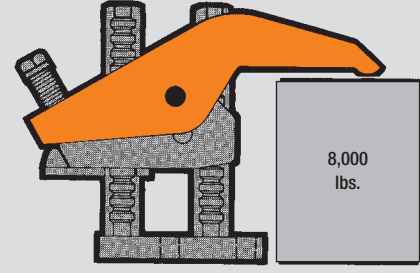
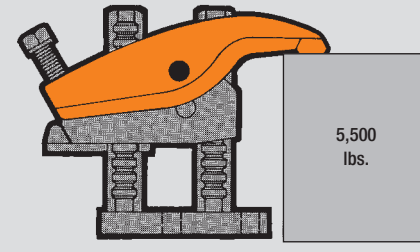
| Holding Capacity [lbs.] | Throat Depth | | Working Height C | | Model No. | Max. Torque | Accessories standard equipment | Weight [lbs.] |
|--|--------------|------|---------------------|-------|-----------|----------------|---|------------------|
| | a | b | min. | max. | | | | |
|  5,000 lbs. | 0.55 | 1.30 | 1.00 | 4.00 | T400-4 | 36 ft. lbs. | 2 T-slot nuts with matching 14 mm bolt | 4.00 |
| | | | 1.00 | 6.00 | T400-6 | | | 4.25 |
| | | | 2.50 | 8.00 | T400-8 | | | 4.60 |
|  3,500 lbs. | 2.24 | 2.87 | 0.50 | 4.00 | T600-4 | 30 ft. lbs. | 2 T-slot nuts with matching 14 mm bolt | 4.80 |
| | | | 0.50 | 6.00 | T600-6 | | | 5.10 |
| | | | 2.00 | 8.00 | T600-8 | | | 5.40 |
|  8,000 lbs. | 1.73 | 2.68 | 0 | 6.00 | T402-6 | 85 ft. lbs. | 2 T-slot nuts with matching 18 mm bolt | 14.00 |
| | | | 0 | 12.00 | T402-12 | | | 17.70 |
| | | | 6.00 | 18.00 | T402-18 | | | 19.40 |
| | | | 12.00 | 24.00 | T402-24 ▲ | | | 20.00 |
|  5,500 lbs. | 3.90 | 4.84 | 0 | 6.00 | T602-6 | 70 ft. lbs. | 2 T-slot nuts with matching 18 mm bolt | 16.00 |
| | | | 0 | 12.00 | T602-12 | | | 19.80 |
| | | | 6.00 | 18.00 | T602-18 ▲ | | | 21.60 |
| | | | 12.00 | 24.00 | T602-24 ▲ | | | 24.30 |
| | | | 18.00 | 30.00 | T602-30 ▲ | | | 28.00 |

▲ Available upon request

These patented clamps provide rapid height adjustment and positive holding. They are designed with a single-unit clamp head and base, providing up to 8,000 lbs. of positive holding capacity for workpieces up to 60" high. The design applies 100% of the screw force directly onto the workpiece far more than any strap clamp arrangement. Additionally, there is no searching for the correct riser block height. The DE-STA-CO CARVER T-Slot Clamp is one single assembly – there are no loose parts.

When setting up, the safety lock on the back is released and the clamp lifted on the base to the desired height. When the clamp screw is turned, 100% of the force is transmitted to the workpiece. Backing off the clamp adjusting screw and releasing the safety lock and lifting the clamp head makes for rapid job changeover.

Safety – No loose parts. Clamp and base are one unit. Higher clamping force holds parts more securely and safely.

Speed – The clamp head adjusts much faster than an operator can select proper size spacers and bolts. Benefits include:

- Cuts set-up time by as much as 80%
- Reduces machine downtime
- Offers more rapid loading and unloading

Economy – Tool tip technology and digital control have reduced machining time. Why lose these advantages on long set-up times? T-Slot clamps can reduce set-up time by as much as 80%. Benefit: Money saved.

Ease of Operation – Loosen adjusting screw and release safety catch to adjust height instantly.

Versatility – Selection of bases gives clamping heights from 0" to 60". Two or more heads can be used on one base to position and hold down as well as support – ideal for fine height adjustment during set-up. Also eliminates riser blocks.

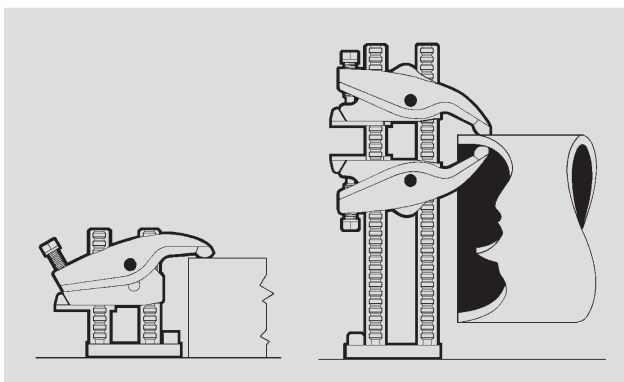

Ideal for use as manual die clamps. Eliminates the need for step blocks or riser blocks.

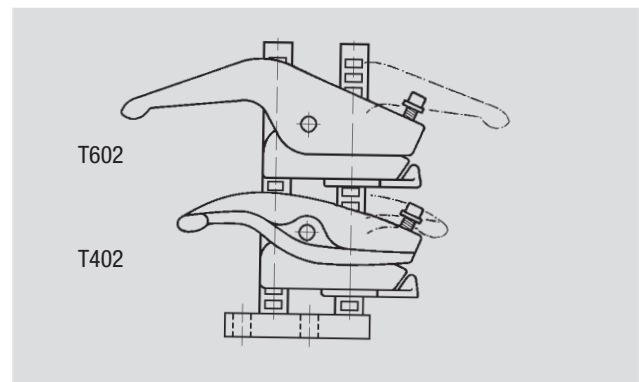

The T402 and T602 can be reversed on their bases to give added reach.

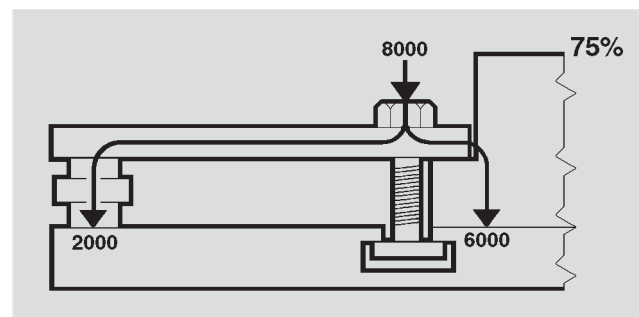
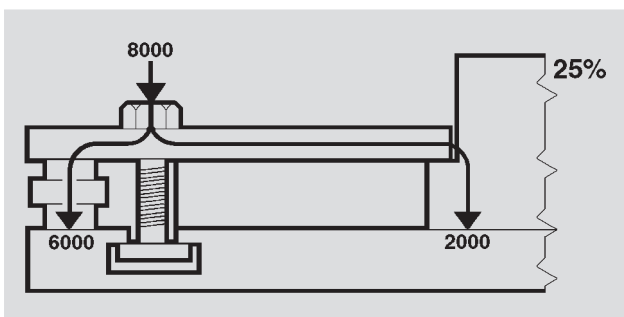
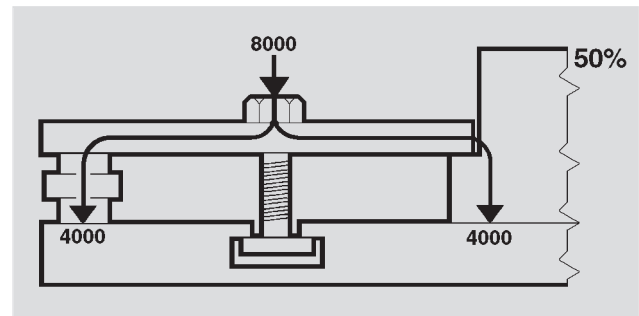
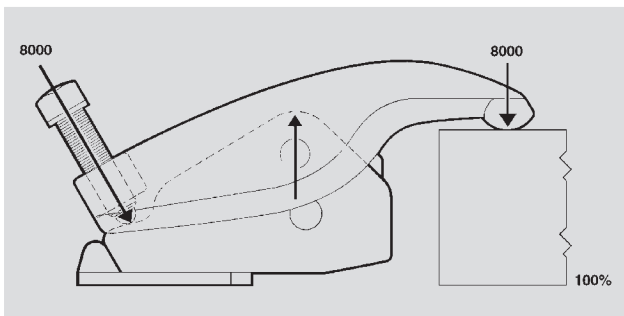

T-Slot Style

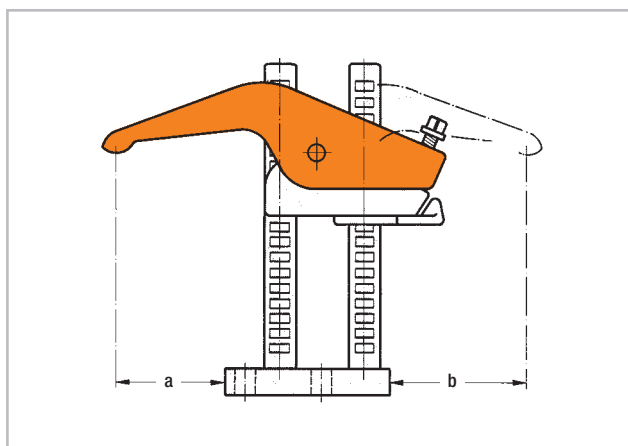
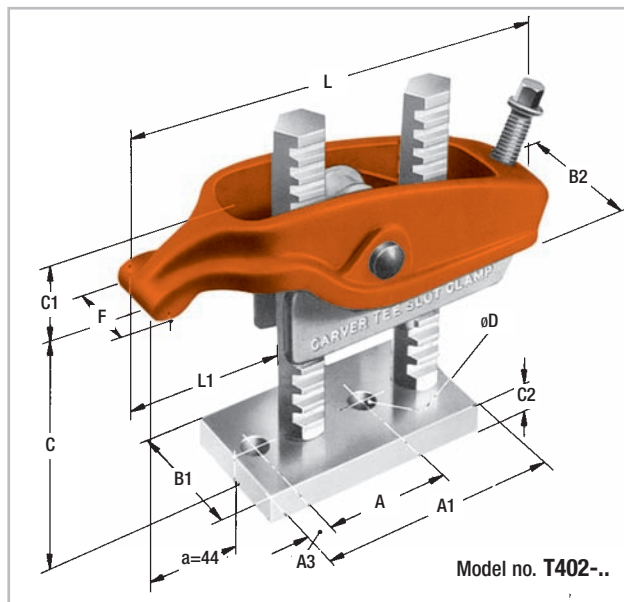
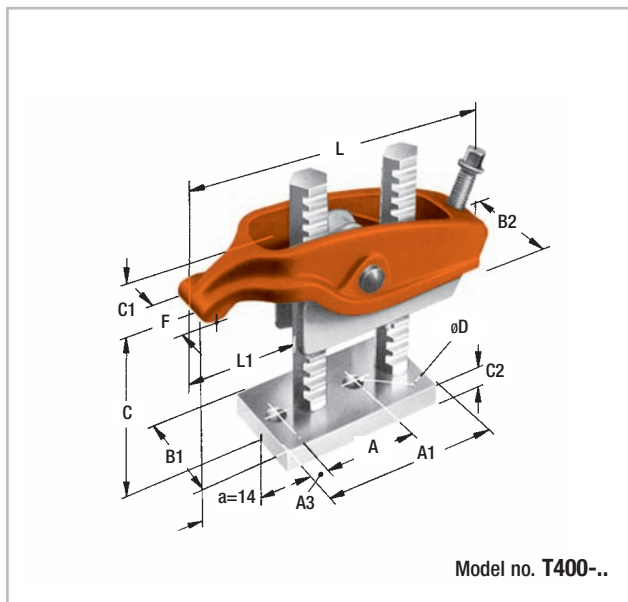

If the T402 is reversed on its base, the measurement of the throat depth will change.

| | T400-.. | T402-.. |
|---|---------|---------|
| a | 0.55 | 1.73 |
| b | 1.30 | 2.68 |

| Model no. | A | A1 | A3 | B1 | B2 | C | C1 | C2 | øD | F | L | L1 | Consisting of | | Clamping Screw Size Ø |
|-----------|------|------|------|------|------|-------|------|------|------|------|------|------|---------------|----------|--------------------------|
| | | | | | | | | | | | | | 1 x | 2 x | |
| T400-4 | 2.12 | 3.78 | 0.45 | 2.00 | 1.03 | 1-4 | 1.09 | 0.63 | 0.53 | 1.02 | 6.31 | 1.44 | 400-2 | 400-4-1 | 12mm |
| T400-6 | 2.12 | 3.78 | 0.45 | 2.00 | 1.03 | 1-6 | 1.09 | 0.63 | 0.53 | 1.02 | 6.31 | 1.44 | 400-2 | 400-6-1 | 12mm |
| T400-8 | 2.12 | 3.78 | 0.45 | 2.00 | 1.03 | 2.5-8 | 1.09 | 0.63 | 0.53 | 1.02 | 6.31 | 1.44 | 400-2 | 400-8-1 | 12mm |
| T402-6 | 2.81 | 5.50 | 0.61 | 3.00 | 3.11 | 0-6 | 1.69 | 0.75 | 0.66 | 1.50 | 9.63 | 2.56 | 402-2 | 402-6-1 | 20mm |
| T402-12 | 2.81 | 5.50 | 0.61 | 3.00 | 3.11 | 0-12 | 1.69 | 0.75 | 0.66 | 1.50 | 9.63 | 2.56 | 402-2 | 402-12-1 | 20mm |
| T402-18 | 2.81 | 5.50 | 0.61 | 3.00 | 3.11 | 6-18 | 1.69 | 0.75 | 0.66 | 1.50 | 9.63 | 2.56 | 402-2 | 402-18-1 | 20mm |
| T402-24 ▲ | 2.84 | 5.50 | 0.61 | 3.00 | 3.11 | 12-24 | 1.69 | 0.75 | 0.66 | 1.50 | 9.63 | 2.56 | 402-2 | 402-24-1 | 20mm |

▲ Available upon request

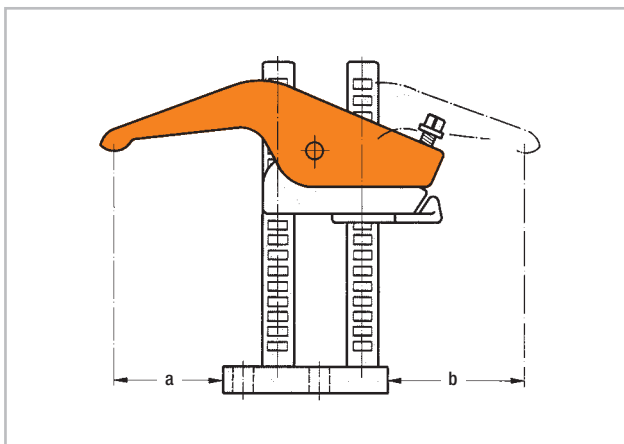
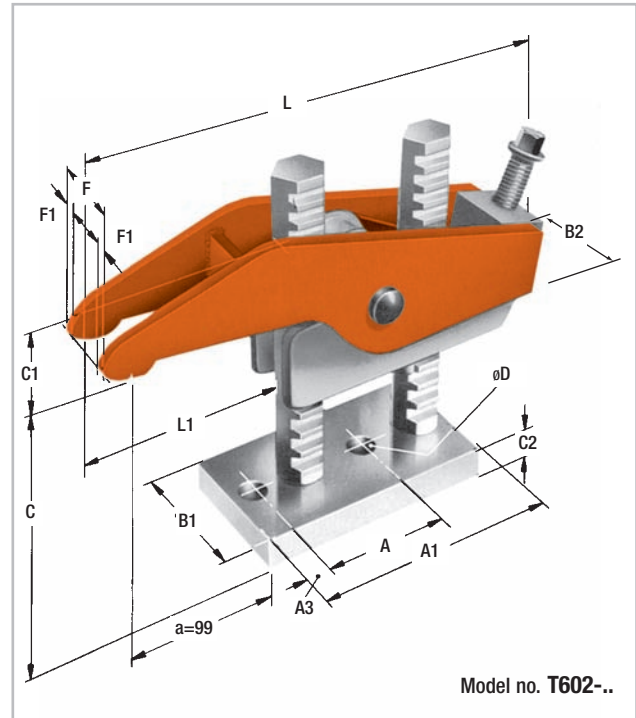
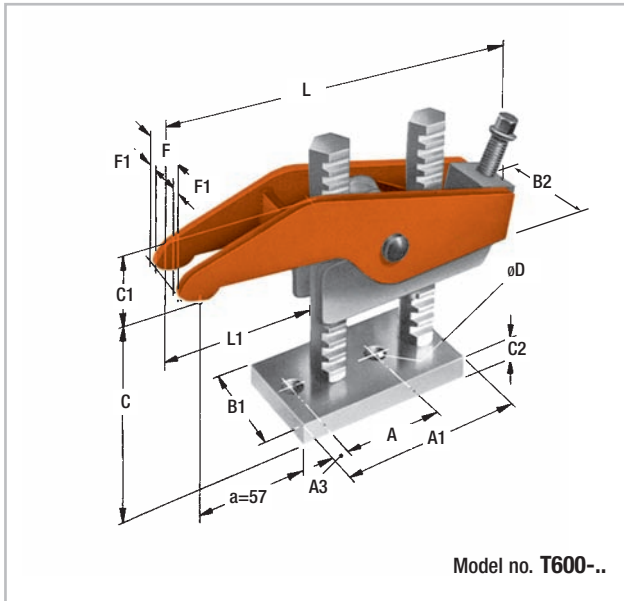

If the T602 is reversed on its base, the measurement of the throat depth will change.

| | T600-.. | T602-.. |
|---|---------|---------|
| a | 2.24 | 3.90 |
| b | 2.87 | 4.84 |

| Model no. | A | A1 | A3 | B1 | B2 | C | C1 | C2 | øD | F | F1 | L | L1 | Consisting of | | Clamping Screw Size Ø |
|-----------|------|------|------|------|------|-------|------|------|------|------|------|-------|------|---|---|--------------------------|
| | | | | | | | | | | | | | | 1 x  | 2 x  | |
| T600-4 | 2.12 | 3.78 | 0.45 | 2.00 | 1.91 | .5-4 | 1.50 | 0.63 | 0.53 | 1.97 | 0.41 | 7.88 | 2.94 | 600-2 | 600-4-1 | 12mm |
| T600-6 | 2.12 | 3.78 | 0.45 | 2.00 | 1.91 | .5-6 | 1.50 | 0.63 | 0.53 | 1.97 | 0.41 | 7.88 | 2.94 | 600-2 | 600-6-1 | 12mm |
| T600-8 | 2.12 | 3.78 | 0.45 | 2.00 | 1.91 | 2-8 | 1.50 | 0.63 | 0.53 | 1.97 | 0.41 | 7.88 | 2.94 | 600-2 | 600-8-1 | 12mm |
| T602-6 | 2.81 | 5.50 | 0.61 | 3.00 | 3.53 | 0-6 | 2.75 | 0.75 | 0.66 | 2.68 | 0.51 | 12.13 | 4.50 | 602-2 | 402-6-1 | 20mm |
| T602-12 | 2.81 | 5.50 | 0.61 | 3.00 | 3.53 | 0-12 | 2.75 | 0.75 | 0.66 | 2.68 | 0.51 | 12.13 | 4.50 | 602-2 | 402-12-1 | 20mm |
| T602-18 ▲ | 2.81 | 5.50 | 0.61 | 3.00 | 3.53 | 6-18 | 2.75 | 0.75 | 0.66 | 2.68 | 0.51 | 12.13 | 4.50 | 602-2 | 402-18-1 | 20mm |
| T602-24 ▲ | 2.81 | 5.50 | 0.61 | 3.00 | 3.53 | 12-24 | 2.75 | 0.75 | 0.66 | 2.68 | 0.51 | 12.13 | 4.50 | 602-2 | 402-24-1 | 20mm |
| T602-30 ▲ | 2.81 | 5.50 | 0.61 | 3.00 | 3.53 | 18-30 | 2.75 | 0.75 | 0.66 | 2.68 | 0.51 | 12.13 | 4.50 | 602-2 | 402-30-1 | 20mm |

▲ Available upon request

