

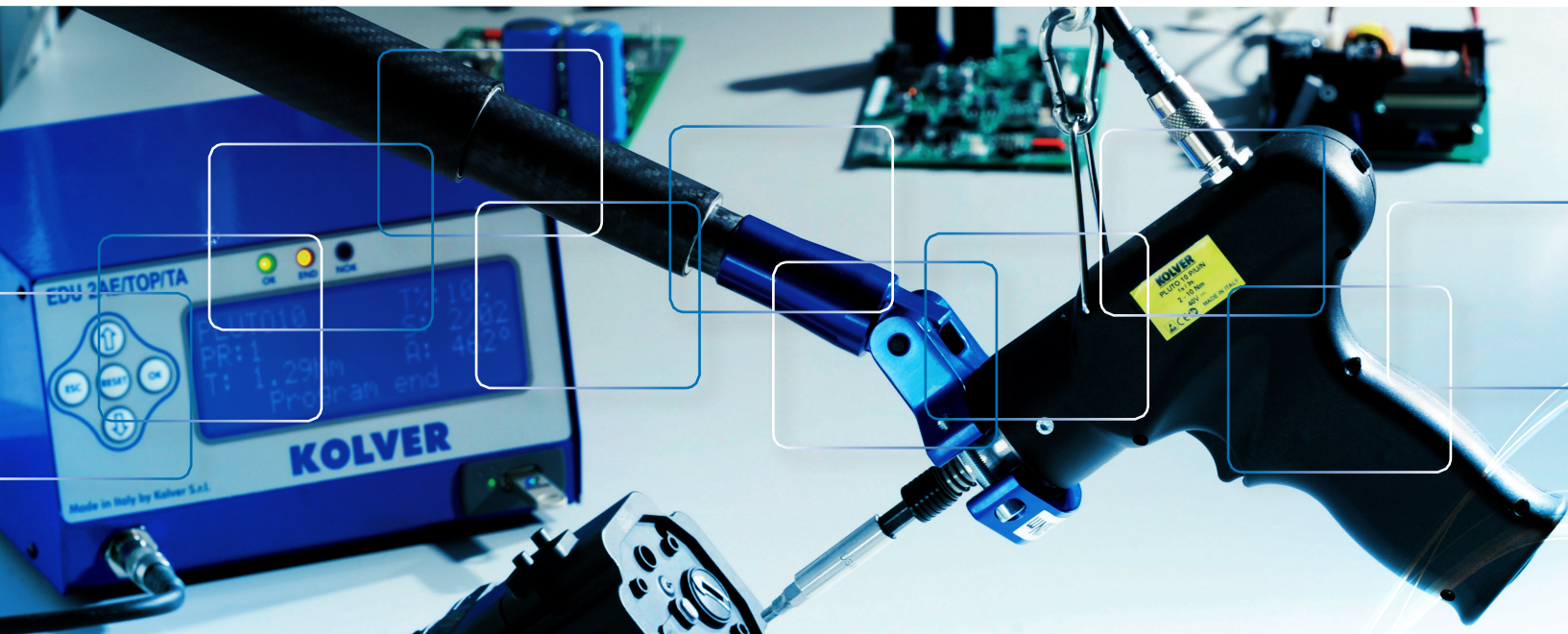

PRECISION SCREW TIGHTENING

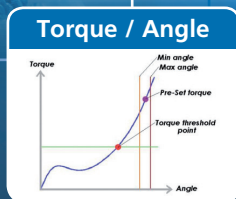

# ELECTRIC SCREWDRIVERS 2017-2018



ELECTRONICS • AUTOMOTIVE • MEDICAL DEVICES  
WHITE GOODS INDUSTRY • GENERAL INDUSTRY

## NATO Screwdrivers – Current Control with Torque Only, or Torque and Angle Capability

**TORQUE UP TO 4.4 in/lbs**

Kolver's experience with current control technology has led to the creation of the NATO screwdrivers; the first ultra-low torque, truly accurate current controlled torque driver designed for applications in which torques below 4.4 in/lbs are required, especially in the mobile industry. The NATO features an innovative electric motor coupled with planetary gearboxes, producing extremely low inertia and minimal friction for long life, and very accurate torque production. NATO Series is available with torque only or torque and angle capabilities.

NATO screwdrivers range in torque from 0.09 – 4.4 in/lbs, and features an ESD-safe housing and cord set or aluminium body (1 inch diameter), for fixture mount applications. Drivers are inline style, with a lever start actuation. NATO systems are available with our 8 P-set programmable controllers for maximum versatility. Foot pedals are available in cases where the operator would like the convenience of manual operation with the NATO/CA series.



NATO for automation with suction head (optional)



EDU2AE/TOP/NT

### Features of the NATO and EDU2AE/TOP/NT System:

- An ultra low torque range of 0.09 – 4.4 in/lbs.
- Speed: ranges from 200–700 RPM.
- DC current controlled low inertia, low voltage iron-less motor.
- The NATO inline driver is also offered as the NATO.. CA fixture mount model for automation and robotic use.
- 0.16 in half moon chuck on NATO15 and Hex 1/4" on NATO50.
- Up to eight (8) P-sets available.
- 1–99 Screws per program.
- Adjustable torque.
- Adjustable Brake (slow speed) time.
- Adjustable Ramp (slow start) time.
- Adjustable Minimum and Maximum rundown time setting.
- Auto reverse setting with adjustable speed and adjustable torque.
- Prevailing Torque (thread cutting) capability.
- Programmable left or right rotation.
- Unscrew lockout capability.
- Programmable controller calibration.
- Nm, lbf.in or kgf.cm setting.
- Adjustable Minimum and Maximum torque setting.
- Barcode, switchbox and socket tray programming capability.
- Programmable sequencing.
- Six language settings.
- Password protected.
- Suction heads specific for NATOs.

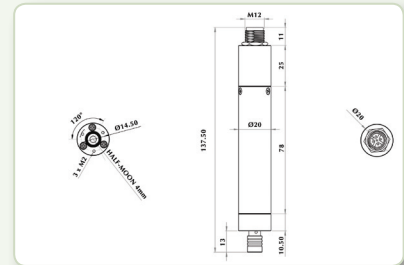

### NATO System with Torque only

Model	Code	Torque in/lbs	RPM min-max	Weight lb	Dimensions in	Style
NATO15D	160015	0.09-1.3	350-700	0.4	7.9x1.3	Inline
NATO15CA	163015	0.09-1.3	350-700	0.3	5.4x0.8	Aluminium body
NATO50D	160050	0.4-4.4	200-700	0.6	8.3x1.3	Inline
NATO50CA	163050	0.4-4.4	200-700	0.4	5.9x1	Aluminium body
EDU2AE/TOP/NT Control unit	031000/TOP/NT	Programmable torque (8 P-sets) with user interface screens		4.4	7.5x8.1x4.7	
EDU2AE/TOP/NT/E Control unit	031000/TOP/NT/E	Like EDU2AE/TOP/NT + remote programming via USB & PC (with EDU EXPAND software)		4.4	7.5x8.1x4.7	

### NATO System with Torque and Angle

Model	Code	Torque in/lbs	RPM min-max	Weight lb	Dimensions in	Style
NATO15D/TA	160015/TA	0.09-1.3	350-700	0.4	7.9x1.3	Inline
NATO15CA/TA	163015/TA	0.09-1.3	350-700	0.3	5.4x0.8	Aluminium body
NATO50D/TA	160050/TA	0.4-4.4	200-700	0.6	8.3x1.3	Inline
NATO50CA/TA	163050/TA	0.4-4.4	200-700	0.4	5.9x1	Aluminium body
EDU2AE/TOP/NT/TA Control unit	031000/TOP/NT/TA	Programmable torque & angle (8 P-sets) with user interface screens		4.4	7.5x8.1x4.7	



## MITO Screwdrivers – Current Control with Torque Only, or Torque and Angle Capability

**TORQUE RANGE FROM 1.8 - 13 in/lbs**

Kolver's experience with current control technology has led to the creation of the MITO series; a truly unique low torque and accurate current controlled torque driver. The MITO features an innovative electric motor coupled with planetary gearboxes, producing extremely low inertia and minimal friction for long life, and very accurate torque production. MITO Series is available in torque, or torque and angle models. Model MITO 15D ranges in torque from 1.8-13 in/lbs, and features an ESD-safe housing and cord set, compact ergonomic design. Drivers are available in pistol or inline style, catering to operator preference and comfort. MITO systems are available with our 8 P-set programmable controllers for maximum versatility. MITO systems work in conjunction with all EDU2AE series controllers for maximum versatility.



EDU2AE/TOP/TA

### Features of the EDU2AE/TOP:

- Up to eight (8) P-sets available.
- Programmable sequencing.
- 1–99 Screws per program.
- Adjustable torque.
- Adjustable Ramp (slow start) time.
- Fast approach speed and a final tightening speed
- Adjustable speed control (450–850 RPM).
- Adjustable Minimum and Maximum rundown time setting.
- Auto reverse setting with adjustable speed and adjustable torque.
- Prevailing Torque (thread cutting) capability.
- Programmable left or right rotation.
- Unscrew lockout capability.
- Programmable controller calibration.
- Nm, lbf.in or kgf.cm setting.
- Adjustable Minimum and Maximum torque setting.
- Barcode, switchbox and socket tray programming capability.
- Multilanguage software.
- Password protected.

### Features of the EDU2AE/TOP/TA:

- All of the above features.
- 6 torque and angle strategies:
  - Torque priority: angle count from torque threshold (T) or from remote input (T/I) or from lever input (T/L).
  - Angle priority: driver stops when angle is reached from threshold torque (A) or from remote input (A/I) or from lever (A/L).

### MITO Screwdrivers

Model	Code	Torque in/lbs	RPM min-max	Weight lb	Dimensions in	Style
MITO15D	170015	1.8-13.3	450-850	0.8	8.5x1.3	Inline
MITO15D/TA (Torque & Angle)	170015/TA	1.8-13.3	450-850	0.9	8.5x1.3	Inline
MITO15P	170014	1.8-13.3	450-850	1.1	7.6x6.3x1.8	Pistol grip

### MITO Control units

Model	Code	Features	Weight lb	Dimensions in
EDU2AE	032000	Programmable with user interface screens	5.3	7.7x6.7x4.3
EDU2AE/HPro	032000/HPro	Like EDU2AE + Torque value, additional signals, Serial Port, serial print, integrated screw counter, Optional screwdriver connector on back panel	5.3	7.7x6.7x4.3
EDU2AE/TOP	032000/TOP	8 different programs - selection by barcode, socket tray, switchbox	5.5	7.5x8.1x4.7
EDU2AE/TOP/E	032000/TOP/E	Like EDU2AE/TOP + remote programming via USB & PC (with EDU EXPAND software)	5.5	7.5x8.1x4.7
EDU2AE/TOP/TA	032000/TOP/TA	Programmable Torque & Angle (8 P-Sets) with user interface screens	5.5	7.5x8.1x4.7



## PLUTO Screwdrivers Current Control Style

TORQUE UP TO 442 in/lbs

Kolver's ingenuity and experience have led to the development of Pluto (PLUs Torque) screwdrivers, the most advanced DC tools in the market, able to reach 442 in/lbs. They feature an innovative coreless electric motor with low inertia and friction with absence of iron losses for extreme efficiency and extended life. Planetary gearboxes with high quality composite materials. Pistol grip to fit operator's hand ergonomically. PLUTO screwdrivers are available in pistol or inline styles; lever, trigger, or push-to-start. All models are ESD safe. Pluto CA/SR series drivers are designed for higher torque applications up to 442 in/lbs. The CA/SR features a sleek design with a robust aluminium body allowing for operator comfort and durability. Torque & Angle models are also available.



PLUTO IN PUSH-TO-START



ANGLE SCREWDRIVERS  
see page 16



PLUTO with LED,  
see page PLUTO..TA



PLUTO20CA/SR

Model	Code	Torque in/lbs	RPM min-max	Dimensions in	Weight lb	Housing
PLUTO3D	130203	4.4-26.6	370-1300	8.9x1.6	1.2	Inline
PLUTO3P	130204	4.4-26.6	370-1300	6.3x6.9x1.8	1.2	Pistol
PLUTO3P/U	130205	4.4-26.6	370-1300	6.4x6.9x1.8	1.2	Pistol grip with top connector
PLUTO3D/PS	130203/PS	4.4-26.6	370-1300	10.4x1.6	1.2	Inline/Push-start
PLUTO6D	130206	7.5-53.1	200-850	8.9x1.6	1.2	Inline
PLUTO6P	130207	7.5-53.1	200-850	6.3x6.9x1.8	1.2	Pistol
PLUTO6P/U	130207/U	7.5-53.1	200-850	6.4x6.9x1.8	1.2	Pistol grip with top connector
PLUTO6D/PS	130206/PS	7.5-53.1	200-850	10.4x1.6	1.2	Inline/Push-start
PLUTO10D/N	130211/N	13.3-88.5	110-600	8.9x1.6	1.2	Inline
PLUTO10P/N	130210/N	13.3-88.5	110-600	6.3x6.9x1.8	1.2	Pistol
PLUTO10P/U/N	130210/U/N	13.3-88.5	110-600	6.4x6.9x1.8	1.2	Pistol grip with top connector
PLUTO10D/PS	130211/PS	13.3-88.5	110-600	10.4x1.6	1.2	Inline/Push-start
PLUTO15D/N	130216/N	17.7-132.8	60-320	8.9x1.6	1.3	Inline
PLUTO15P/N	130215/N	17.7-132.8	60-320	6.3x6.9x1.8	1.3	Pistol
PLUTO15P/U/N	130215/U/N	17.7-132.8	60-320	6.4x6.9x1.8	1.3	Pistol grip with top connector
PLUTO15D/PS	130216/PS	17.7-132.8	60-320	10.4x1.6	1.3	Inline/Push-start
PLUTO20CA/SR	133221/SR	26.6-177	50-200	9.1x2.1	2.4	Aluminium body, start/reverse buttons
PLUTO35CA/SR	133236/SR	26.6-309.8	40-140	9.7x2.2	3.3	Aluminium body, start/reverse buttons
PLUTO50CA/SR	133250/SR	44.3-442.5	20-90	9.9x2.2	3.3	Aluminium body, start/reverse buttons



## PLUTO Screwdriver Clutch Style

**TORQUE RANGE 4.4 - 62.0 in/lbs**

PLUTO clutch screwdrivers are innovative state-of-the-art screwdrivers. High-efficiency and low inertia CORELESS motors allow high performances on any kind of joint. The new clutch for the regulation of the tightening torque guarantees an excellent accuracy, i.e. 3% on the whole torque range, which means our PLUTOs feature the best CP and CM in the market.

PLUTO screwdrivers fulfill the highest environmental protection requirements: minimal vibrations, maximum safety, low noise level, electromagnetic compatibility, no polluting emissions, low energy consumption.

They all come standard with ESD-safe body. The range features three inline and three pistol models for manual use, plus their corresponding models for automated applications.

They work with EDU2AE/FR, the control unit specifically designed for PLUTO/FR screwdrivers, but they're also compatible with the complete EDU2AE series (PLUTO/FR/TA are meant to be used with EDU2AE/TOP/TA only).

PLUTO/FR come standard with ESD-safe body, suspension bail and 8.2 ft connection cable. Spiral cable available on request. The new heavy duty cables and connectors, developed for robotic applications, are made of antistatic dissipative material for safe use in an EPA environment.

Model	Code	Torque in/lbs	RPM min-max	Dimensions in	Weight lb	Housing
PLUTO3FR	131203	4.4-28.3	800-1300	10.8x1.6	1.2	Inline
PLUTO3FR/P	131204	4.4-28.3	800-1300	6.2x8.8x1.8	1.2	Pistol
PLUTO3FR/P/U	131204/U	4.4-28.3	800-1300	6.4x9.1x1.8	1.2	Pistol grip with top connector
PLUTO5FR	131205	6.2-44.3	600-1000	10.8x1.6	1.2	Inline
PLUTO5FR/P	131206	6.2-44.3	600-1000	6.2x8.8x1.8	1.2	Pistol
PLUTO5FR/P/U	131206/U	6.2-44.3	600-1000	6.4x9.1x1.8	1.2	Pistol grip with top connector
PLUTO7FR	131207	13.3-62	350-600	10.8x1.6	1.2	Inline
PLUTO7FR/P	131208	13.3-62	350-600	6.2x8.8x1.8	1.2	Pistol
PLUTO7FR/P/U	131208/U	13.3-62	350-600	6.4x9.1x1.8	1.2	Pistol grip with top connector
PLUTO3FR/CA	133203	4.4-28.3	800-1300	9.9x1.6	1.7	Aluminium body
PLUTO3FR/CA/FN	133203/FN	4.4-28.3	800-1300	12.9x1.6	1.8	Aluminium body, telescopic spindle
PLUTO5FR/CA	133205	6.2-44.3	600-1000	9.9x1.6	1.7	Aluminium body
PLUTO5FR/CA/FN	133205/FN	6.2-44.3	600-1000	12.9x1.6	1.8	Aluminium body, telescopic spindle
PLUTO7FR/CA	133207	13.3-62	350-600	9.9x1.6	1.7	Aluminium body
PLUTO7FR/CA/FN	133207/FN	13.3-62	350-600	12.9x1.6	1.8	Aluminium body, telescopic spindle
PLUTO3FR/TA	131203/TA	4.4-28.3	800-1300	10.8x1.6	1.2	Inline
PLUTO5FR/TA	131205/TA	6.2-44.3	600-1000	10.8x1.6	1.2	Inline
PLUTO7FR/TA	131207/TA	13.3-62	350-600	10.8x1.6	1.2	Inline



EDU2AE



EDU2AE/HPro



EDU2AE/TOP



EDU2AE/TOP/E



EDU2AE/TOP/TA

## PLUTO Control Units Single & Multi-Torque

EDU2AE Series Switching Controllers act as an AC to DC transformer and torque controller. The electronic control circuit cuts the power supply to the motor as soon as the pre-set torque has been reached. The whole EDU2AE Series is now totally renovated and fully upgraded with our state-of-the-art advanced software for torque controlling. The main features of the new switching control units are:

- Universal usage: All units are equipped with a high power switching transformer with 90-260 V AC power supply: 100% more power and 40% weight reduction.
- New software: EDU2AE & EDU2AE/HPro have a 2.00 version, all TOP units a 5.00 version installed.
- More accurate than ever: The combination of the switching transformer and new software allows MITO & PLUTO screwdrivers to reach a much higher accuracy, better than +/- 5% all over the torque range.
- Better endurance in environment with high noise and interference level: All units comply to norms 61000-6-2 and 61000-6-3.
- Improved EMC features: All units are equipped with a solid steel base and back panel.
- New Features: Users are able to select a fast approach speed and a final tightening speed to adapt to any type of application. It is also possible to select an endless time of clockwise rotation for any application requiring no max time option.
- Multilanguage: English, Italian, German, French, Portuguese, Spanish.

EDU2AE control units can be used in combination with any Kolver current controlled MITO and PLUTO and/or clutch PLUTO screwdriver.

An easy-to-use scroll menu allows to select, set and/or adjust the following functions:

- Screwdriver model
- Tightening torque, fastening and unscrewing speed
- Acceleration ramp
- Min and Max fastening time
- Autoreverse

The EDU2AE/TOP multiple torque system is designed to expand the functionality of PLUTO screwdrivers by enabling multiple torque settings (up to 8) using one controller and one driver. All functions can also be controlled remotely via 15 input and 11 output connectors, which can be connected to one of our optional accessories such as Switch Box, Socket/Bit Tray, Bar Code Scanner, Printer and Ethernet assist.

EDU2AE/TOP/E has all of the features of the standard EDU2AE/TOP and the Expand software package for remote programming via USB port & PC.

The features of the EDU2AE/TOP/E come standard with EDU2AE/TOP/TA, the torque and angle control unit (see page 10).

Model	Code	Features	Dimensions in	Weight lb
EDU2AE	032000	Programmable with user interface screens	7.7x6.7x4.3	5.3
EDU2AE/FR	032000/FR	For PLUTO..FR series. Like EDU2AE + Run time, Integrated screw counter, Additional signals, Serial Port, Optional screwdriver connector on back panel	7.7x6.7x4.3	5.3
EDU2AE/HPro	032000/HPro	Like EDU2AE + Torque value, Run Time, Additional signals, Serial Port, serial print, integrated screw counter, Optional screwdriver connector on back panel	7.7x6.7x4.3	5.3
EDU2AE/TOP	032000/TOP	8 different programs - selection by barcode, socket tray, switchbox	7.5x8.1x4.7	5.5
EDU2AE/TOP/E	032000/TOP/E	Like EDU2AE/TOP + remote programming via USB & PC (with EDU EXPAND software)	7.5x8.1x4.7	5.5
EDU2AE/TOP/TA	032000/TOP/TA	Programmable Torque & Angle (8 P-Sets) with user interface screens	7.5x8.1x4.7	5.5

## PLUTO Control Units – TOP EXPAND



EDU2AE/TOP/E



EDU2AE/TOP/TA

The EDU2AE/TOP/E and the improved version of our EDU2AE/TOP/TA are now available with programming software. Each control unit is supplied standard with EDU EXPAND software and an 8Gb USB flash drive. An external WiFi device is available on request.

Main features:

**PC programming** (back panel): it is possible to set, change and save all parameters through our new "EDU EXPAND" software for PC. EDU EXPAND communicates with the control unit via mini-USB or RS232.

**Saving/programming on USB flash drive** (front panel): you can now save the results of each screwing operation directly on USB pen drive! It is also possible to upload via USB drive all parameters/programs previously set on "EDU EXPAND". Just connect your USB to the port and recall the desired programs on the menu. The programs set on control unit can be downloaded on USB and recalled on another unit and on EDU EXPAND, too.

## EDU2AE Switching Control Units

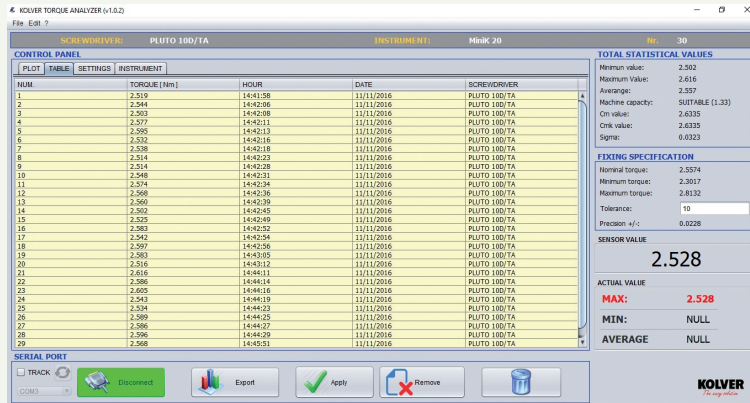

The EDU2AE series of controllers for MITO & PLUTO screwdrivers has been totally renovated and fully upgraded to improve the system performances. Thanks to the new state-of-the-art advanced software for torque controlling it is now possible to reach the most accurate results with CM / CMK values higher than ever! All units are meant for universal usage and are equipped with a high power switching transformer with 90-260 V AC power supply for 100% more power and 40% weight reduction. The combination of the switching transformer and new software allows the MITO & PLUTO screwdrivers to reach a much higher accuracy, better than +/- 5% all over the torque

range. All units comply to norms 61000-6-2 and 61000-6-3 and therefore have better endurance in environments with high noise and interference levels. Improved EMC features are guaranteed thanks to solid steel base and back panel. The new features allow users to select a fast approach speed and a final tightening speed to adapt to any type of application and it is also possible to select an endless time of clockwise rotation for any application requiring no max time option. The new EDU2AE control units are now multilanguage: you can choose among English, Italian, German, French, Portuguese or Spanish. A wide range of accessories for remote programming and PC interface is available for the complete EDU2AE series.



ETHERNET DEVICE  
code 020075



SWITCHBOX SWBX88  
code 020033



BAR CODE SCANNER  
code 020050



SOCKET TRAY CBS880  
code 020042

## CA Screwdrivers

The CA screwdrivers are designed for automated and fixtured applications. Special wiring and dedicated controllers are equipped with electric signals and contacts for immediate and easy interface. The ideal alternative to pneumatic drivers, they feature a long life maintenance free electric motor with a unique electronic torque control system for high accuracy throughout a wide torque range (up to 442 in/lbs); an aluminium body, for easy and quick clamp, supplied with 8.2 ft cable.

The PLUTO..CA/FN2 Series incorporates the PLUTO DC-controlled electric screwdriver design, supplied in an inline aluminium housing for flange mounting applications. The DC motor and solid state controls of the PLUTO are ideal for automated high volume/high duty applications. Flange and telescopic spindle available together or separately. 3D drawings available on [www.kolverusa.com](http://www.kolverusa.com)



TELESCOPIC SPINDLE

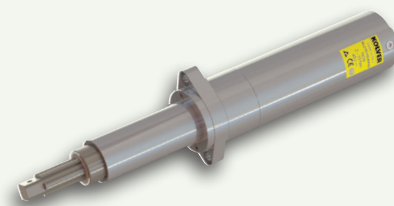

PLUTO..CA/FN2

Model	Code	Torque in/lbs	RPM min-max	Dimensions in	Weight lb	Output	Control unit
NATO15CA	163015	0.09-1.3	350-700	5.4x0.8	0.3	Half moon 4mm	EDU2AE/TOP/NT
NATO50CA	163050	0.4-4.4	200-700	5.9x1	0.4	Hex 1/4"	EDU2AE/TOP/NT
MITO15CA	170016	1.8-13.3	450-850	7.6x1.3	0.8	Hex 1/4"	EDU2AE Series
MITO15CA/FN	170016/FN	1.8-13.3	450-850	10.7x1.3	1.0	Hex 1/4"	EDU2AE Series
PLUTO3CA	130303	4.4-26.6	370-1300	6.6x1.6	1.1	Hex 1/4"	EDU2AE Series
PLUTO3CA/FN2	130303/FN2	4.4-26.6	370-1300	10.6x1.6	1.5	Sq 3/8"	EDU2AE Series
PLUTO6CA	133206	7.5-53.1	200-850	6.6x1.6	1.1	Hex 1/4"	EDU2AE Series
PLUTO6CA/FN2	133206/FN2	7.5-53.1	200-850	10.6x1.6	1.5	Sq 3/8"	EDU2AE Series
PLUTO10CA/N	133211/N	13.3-88.5	110-600	6.6x1.6	1.1	Hex 1/4"	EDU2AE Series
PLUTO10CA/FN2	133211/FN2	13.3-88.5	110-600	10.6x1.6	1.5	Sq 3/8"	EDU2AE Series
PLUTO15CA/N	133216/N	17.7-132.8	60-320	6.6x1.6	1.1	Hex 1/4"	EDU2AE Series
PLUTO15CA/FN2	133216/FN2	17.7-132.8	60-320	10.6x1.6	1.5	Sq 3/8"	EDU2AE Series
PLUTO20CA	133221	26.6-177	50-200	9.1x1.9	2.4	Sq 3/8"	EDU2AE Series
PLUTO20CA/FN	133221/FN	26.6-177	50-200	12.7x1.9	3.0	Sq 3/8"	EDU2AE Series
PLUTO35CA	133236	26.6-309.8	40-140	9.7x2.2	3.3	Sq 3/8"	EDU2AE Series
PLUTO35CA/FN	133236/FN	26.6-309.8	40-140	13.3x2.2	4.3	Sq 3/8"	EDU2AE Series
PLUTO50CA	133250	44.3-442.5	20-90	9.9x2.2	3.3	Sq 1/2"	EDU2AE Series
PLUTO50CA/FN	133250/FN	44.3-442.5	20-90	13.8x2.2	4.3	Sq 1/2"	EDU2AE Series
KBL04FR/CA	190004/CA	0.4-3.5	650-1000	10.1x1.6	1.3	Hex 1/4"	EDU1BL/SG
KBL04FR/CA/FN	190004/CA/FN	0.4-3.5	650-1000	13x1.6	1.4	Hex 1/4"	EDU1BL/SG
KBL15FR/CA	190015/CA	3.5-13.3	650-1000	10.1x1.6	1.3	Hex 1/4"	EDU1BL/SG
KBL15FR/CA/FN	190015/CA/FN	3.5-13.3	650-1000	13x1.6	1.4	Hex 1/4"	EDU1BL/SG
KBL30FR/CA	190030/CA	6.2-26.6	650-1000	10.4x1.6	1.7	Hex 1/4"	EDU1BL/SG
KBL30FR/CA/FN	190030/CA/FN	6.2-26.6	650-1000	13.3x1.6	1.8	Hex 1/4"	EDU1BL/SG
KBL40FR/CA	190040/CA	8-35.4	450-750	10.4x1.6	1.7	Hex 1/4"	EDU1BL/SG
KBL40CA/FN	190040/CA/FN	8-35.4	450-750	13.3x1.6	1.8	Hex 1/4"	EDU1BL/SG

All CA are also available with torque and angle excluding the KBL series. Drawings and manuals available on [www.kolverusa.com](http://www.kolverusa.com)



## CA Control Units

All Kolver Current Controlled screwdrivers work in combination with a control unit acting as an AC to DC transformer, and torque controller. Our exclusively designed circuitry monitors the power supply, and cuts power to the driver motor once the pre-set torque has been reached.

For the Pluto CA Series, the EDU 2AE Series controllers give the precise torque control for all automated operations at a fraction of the cost of transducer tools. The whole EDU2AE Series is now totally renovated and fully upgraded with our state-of-the-art advanced software for torque controlling. The main features of the new switching control units are:

- Universal usage: All units are equipped with a high power switching transformer with 90-260 V AC power supply: 100% more power and 40% weight reduction.
- New software: EDU2AE & EDU2AE/HPro have a 2.00 version, all TOP units a 5.00 version installed.
- More accurate than ever: The combination of the switching transformer and new software allows MITO & PLUTO screwdrivers to reach a much higher accuracy, better than +/- 5% all over the torque range.
- Better endurance in environment with high noise and interference level: All units comply to norms 61000-6-2 and 61000-6-3.
- Improved EMC features: All units are equipped with a solid steel base and back panel.
- New Features: Users are able to select a fast approach speed and a final tightening speed to adapt to any type of application. It is also possible to select an endless time of clockwise rotation for any application requiring no max time option.
- Multilanguage: English, Italian, German, French, Portuguese, Spanish.



EDU2AE



EDU2AE/TOP/TA



EDU2AE/TOP/E



EDU1BL/SG



MULTI SPINDLE

The EDU1BL/SG control unit is designed to work with our KBL Brushless drivers. These KBL drivers feature a maintenance free brushless motor, and the EDU controllers feature state-of-the-art electronics with zero wearing components.

Controllers come standard with:

- Slow start adjustment.
- RPM adjustment (60% to 100% of rated speed).
- Visual indicators (red-green) for power and torque.
- Input: Start and Reverse contacts.
- Output: 24 V DC for torque reached and lever signals.

Kolver also features Multi-Spindle units, including Pluto or Brushless controllers, CA spindles, all custom fixturing, and master PLC.

We invite you to contact us for further information.

Model	Code	Features	Dimension in	Weight lb
EDU2AE	032000	Programmable with user interface screens	7.7x6.7x4.3	5.3
EDU2AE/FR	032000/FR	For PLUTO..FR series. Like EDU2AE + Run time, Integrated screw counter, Additional signals, Serial Port, Optional screwdriver connector on back panel	7.7x6.7x4.3	5.3
EDU2AE/HPro	032000/HPRO	Like EDU2AE + Torque value, Run Time, Additional signals, Serial Port, serial print, integrated screw counter, Optional screwdriver connector on back panel	7.7x6.7x4.3	5.3
EDU2AE/TOP	032000/TOP	8 different programs - selection by barcode, socket tray, switchbox	7.5x8.1x4.7	5.5
EDU2AE/TOP/E	032000/TOP/E	Like EDU2AE/TOP + remote programming via USB & PC (with EDU EXPAND software)	7.5x8.1x4.7	5.5
EDU2AE/TOP/TA	032000/TOP/TA	Programmable Torque & Angle (8 P-Sets) with user interface screens	7.5x8.1x4.7	5.5
EDU1BL/SG	003000/SG	Output signals: torque, error and lever; Input signals: start, stop and reverse. For KBL/S and KBL/CA.	5.4x4.6x2.6	1.3



## Electric Screwdrivers with Torque & Angle Control

Industrial tightening may require different control strategies and solutions. The most common cases are: torque control with angle monitoring and angle control with torque monitoring. Kolver Multi-Torque Torque & Angle controllers can manage all such strategies, with up to 8 individual P-sets.

### The Torque/Angle Control

The main parameters to be controlled are the tightening torque and the rotation angle of the screw, either with torque or angle priority. The motor stops automatically when the pre-set angle and torque value have been reached and an indication of OK cycle (green led turned on) is given, otherwise a red led turns on if the tightened screw doesn't match the pre-set parameters. The final torque and angle values are also displayed.

Thanks to the new state-of-the-art advanced software for torque controlling it is now possible to reach the most accurate results with CM / CMK values higher than ever.

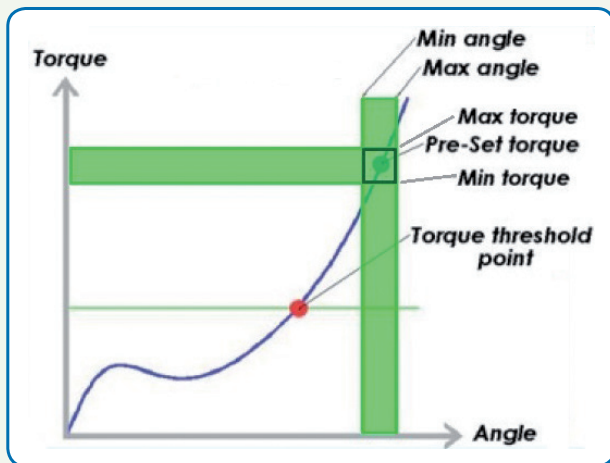

**TORQUE:** It's the most common mode. The control unit shows the tightening torque and the torque starting from a certain torque percentage (threshold torque). If the final torque and angle values are within the preset minimum and maximum values, the screw is tightened correctly. If the torque and/or angle are outside the preset values, the screw will be considered incorrectly tightened. In this case the red led will light up and the message "Error Max (Min) Angle" or "Error Max (Min) Torque" will be displayed.

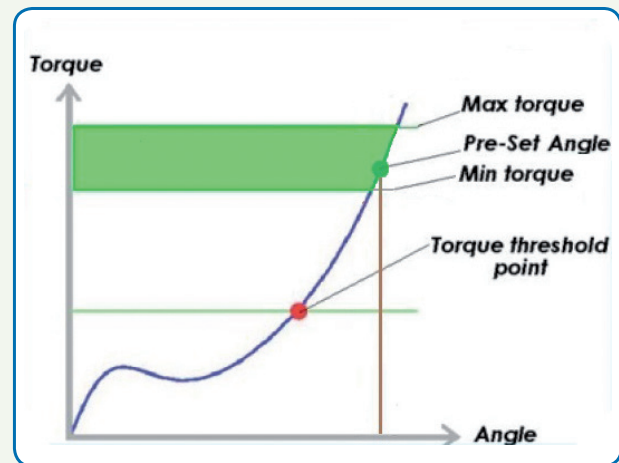

**ANGLE:** This mode gives priority to the angle to be reached. The value is measured starting from a tightening torque percentage. Starting from the preset threshold torque the system will start counting the degrees and when the preset angle is reached the screwdriver will stop. If the preset angle is reached the screw will be considered correctly tightened, the green led will light up and the message "tightening OK" will be displayed on the status bar. If the screwdriver stops before reaching the preset angle the tightening will be considered not ok, the red led will light up and the message "error angle not reached" will be displayed on the status bar. It is also possible to set minimum and maximum values within which the set angle must be reached.

**Main features:**

- New Expand software package for remote programming via USB port and PC.
- USB port on the front of the controller for uploading and downloading programs.
- Easy to program user interface screens.
- Password protected.
- Torque value in Nm, lbf.in and kgf.cm.
- Angle value in degrees.
- 8 independent programs including the options:
  - Min/Max torque value.
  - Min/Max angle value.
  - Rundown speed.
  - Slow start/Soft stop.
  - Hard/soft joint.
  - Min/Max rundown time.
  - Prevailing torque (threadcutting).
  - Auto reverse if required.
- 6 torque & angle strategies:
  - Torque priority: angle count from torque threshold (T) or from remote input (T/I) or from lever input (T/L).
  - Angle priority: driver stops when angle is reached from threshold torque (A) or from remote input (A/I) or from lever (A/L).

Model	Code	Torque in/lbs	RPM min-max	Dimensions in	Output	Style	To be used with
NATO15D/TA	160015/TA	0.09-1.3	350-700	7.9x1.3	Half moon 4mm	Inline	EDU2AE/TOP/NT/TA
NATO50D/TA	160050/TA	0.4-4.4	200-700	8.3x1.3	Hex 1/4"	Inline	EDU2AE/TOP/NT/TA
MITO15D/TA	170015/TA	1.8-13.3	450-850	8.5x1.3	Hex 1/4"	Inline	EDU2AE/TOP/TA
PLUTO3D/TA	130203/TA	4.4-26.6	370-1300	8.9x1.6	Hex 1/4"	Inline	EDU2AE/TOP/TA
PLUTO3D/TA/LED	130203/TA/LED	4.4-26.6	370-1300	8.9x1.6	Hex 1/4"	Inline, with LED	EDU2AE/TOP/TA
PLUTO3P/TA	130204/TA	4.4-26.6	370-1300	6.3x6.9x1.8	Hex 1/4"	Pistol	EDU2AE/TOP/TA
PLUTO6D/TA	130206/TA	7.5-53.1	200-850	8.9x1.6	Hex 1/4"	Inline	EDU2AE/TOP/TA
PLUTO6D/TA/LED	130206/TA/LED	7.5-53.1	200-850	8.9x1.6	Hex 1/4"	Inline, with LED	EDU2AE/TOP/TA
PLUTO6P/TA	130207/TA	7.5-53.1	200-850	6.3x6.9x1.8	Hex 1/4"	Pistol	EDU2AE/TOP/TA
PLUTO10D/TA	130211/TA	13.3-88.5	110-600	8.9x1.6	Hex 1/4"	Inline	EDU2AE/TOP/TA
PLUTO10D/TA/LED	130211/TA/LED	13.3-88.5	110-600	8.9x1.6	Hex 1/4"	Inline, with LED	EDU2AE/TOP/TA
PLUTO10P/TA	130210/TA	13.3-88.5	110-600	6.3x6.9x1.8	Hex 1/4"	Pistol	EDU2AE/TOP/TA
PLUTO15D/TA	130216/TA	17.7-132.8	60-320	8.9x1.6	Hex 1/4"	Inline	EDU2AE/TOP/TA
PLUTO15D/TA/LED	130216/TA/LED	17.7-132.8	60-320	8.9x1.6	Hex 1/4"	Inline, with LED	EDU2AE/TOP/TA
PLUTO15P/TA	130215/TA	17.7-132.8	60-320	6.3x6.9x1.8	Hex 1/4"	Pistol	EDU2AE/TOP/TA
PLUTO20CA/SR/TA	133221/SR/TA	26.6-177	50-200	9.1x2.1	Sq 3/8"	Aluminium body, start/reverse buttons	EDU2AE/TOP/TA
PLUTO35CA/SR/TA	133236/SR/TA	26.6-309.8	40-140	9.7x2.2	Sq 3/8"	Aluminium body, start/reverse buttons	EDU2AE/TOP/TA
PLUTO50CA/SR/TA	133250/SR/TA	44.3-442.5	20-90	9.9x2.2	Sq 1/2"	Aluminium body, start/reverse buttons	EDU2AE/TOP/TA
EDU2AE/TOP/TA Control unit	032000/TOP/TA						Any PLUTO../TA and MITO../TA
EDU2AE/TOP/NT/TA Control unit	031000/TOP/NT/TA						NATO../TA Series

## FAB & RAF Screwdrivers

TORQUE UP TO 44.3 in/lbs

FAB series electric screwdrivers are our “best sellers” for the electronic industry. RAF series screwdrivers are designed to meet higher torque applications. Their advanced ergonomic design, ease of use, high accuracy and durability have made these drivers the standard by which all others are measured. They are light-weight, compact, powerful and come standard with ESD-safe housing certified to SP method 2472 (Ericsson approved). These screwdrivers are available in an inline body style with either a lever start or push to start or in a pistol grip with a trigger start (also available with the cord coming out from the top - U option) and different speeds, for different assembly requirements. The torque is set externally: an adjusting nut controls output torque by changing the clutch spring compression.

A reference scale will indicate the torque setting. The low voltage 30 VDC rare earth motors combine high performances and long life. Replacing their carbon brushes once a year is all you need for maintenance. The motor works in combination with a control unit. The electronic control circuit cuts the power supply to the motor in response to the clutch action, as soon as the pre-set torque has been reached. In addition the controller can be supplied with torque reached signal, lever signal, remote start and reverse (see page of control units for all the details) and with ACE screw counter unit.

All FAB and RAF drivers come standard with ESD-safe body, suspension bail and 8.2 ft connection cable. Spiral cable available on request. The new heavy duty cables and connectors, developed for robotic applications, are made of antistatic dissipative material for safe use in an EPA environment.



ANGLE HEAD

Model	Code	Torque in/lbs	RPM min-max	Start option	Weight lb	Dimensions in	Style
FAB03SS/FR	110003/FR	0.4-2.7	450-650	Lever	1.1	9.3x1.3	Inline
FAB10RE/FR	110010/FR	0.4-7.1	600-1000	Lever	1.1	9.3x1.3	Inline
FAB12RE/FR	110012/FR	1.8-10.6	600-1000	Lever	1.1	9.3x1.3	Inline
FAB12PS/FR	112012/FR	1.8-10.6	600-1000	Push start	1.1	9.8x1.3	Inline
FAB12PP/FR	110013/FR	1.8-10.6	600-1000	Lever	1.2	8.7x6.3x1.7	Pistol
FAB12PP/FR/U	110013/FR/U	1.8-10.6	600-1000	Lever	1.2	8.7x6.4x1.7	Pistol grip with top connector
FAB18RE/FR	110618/FR	2.7-16	450-650	Lever	1.1	9.3x1.3	Inline
FAB18PS/FR	112618/FR	2.7-16	450-650	Push start	1.1	9.8x1.3	Inline
FAB18PP/FR	110619/FR	2.7-16	450-650	Lever	1.2	8.7x6.3x1.7	Pistol
FAB18PP/FR/U	110619/FR/U	2.7-16	450-650	Lever	1.2	8.7x6.4x1.7	Pistol grip with top connector
RAF32NS/FR	120032/FR	6.2-28.3	600-1000	Lever	1.4	10.2x1.6	Inline
RAF32PS/FR	122032/FR	6.2-28.3	600-1000	Push start	1.4	10.6x1.6	Inline
RAF32PP/FR	120033/FR	6.2-28.3	600-1000	Lever	1.5	8.7x6.3x1.7	Pistol
RAF32PP/FR/U	120033/FR/U	6.2-28.3	600-1000	Lever	1.5	8.7x6.4x1.7	Pistol grip with top connector
RAF38NS/FR	120638/FR	8-33.6	450-650	Lever	1.4	10.2x1.6	Inline
RAF38PS/FR	122638/FR	8-33.6	450-650	Push start	1.4	10.6x1.6	Inline
RAF38PP/FR	120639/FR	8-33.6	450-650	Lever	1.5	8.7x6.3x1.7	Pistol
RAF38PP/FR/U	120639/FR/U	8-33.6	450-650	Lever	1.5	8.7x6.4x1.7	Pistol grip with top connector
RAF50NS/FR	120650/FR	8-44.3	400-700	Lever	1.4	10.2x1.6	Inline
RAF50PS/FR	122650/FR	8-39.8	400-700	Push start	1.4	10.6x1.6	Inline
RAF50PP/FR	120651/FR	8-44.3	400-700	Lever	1.5	8.7x6.3x1.7	Pistol
RAF50PP/FR/U	120651/FR/U	8-44.3	400-700	Lever	1.5	8.7x6.4x1.7	Pistol grip with top connector

## FAB & RAF Control Units

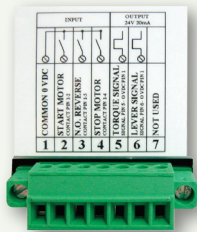

**BACK CONNECTOR  
(EDU1FR/SG ONLY)**

All Kolver screwdrivers work in combination with a control unit acting as an AC to DC transformer and torque controller. The electronic control circuit cuts the power supply to the motor as soon as the pre-set torque has been reached. The EDU1FR control units for FAB and RAF screwdrivers feature a maintenance free state-of-the-art electronics, with no wearing components with a circuit design suitable to both lever start and push start drivers with protection against current overload up to 10A. This design results in very low current to the driver's start switch and clutch switch to extend their life indefinitely. Additional features:

- Suitable to universal supply from 90 to 260 V ac 50/60 hz.
- Slow start (0-2 seconds) and RPM (60% to 100%).
- Visual indicators (green–red) for power on/off and clutch action.
- Reduced weight (1.3 lbs) and compact size for easy placement.
- M12 waterproof connector with silver and gold contacts for perfect conductivity.

The EDU1FR/SG controller features additional circuits wired to one connector in the back panel: output 24V for torque reached and lever signals; input start and reverse contacts. A double output connector (DOCK01) is also available for operators using two screwdrivers on the same working area (only FAB and RAF series). One end of this device is to be connected to the controller (cable included), the other end to the drivers. The screwdrivers are not to be used at the same time.

FAB and RAF screwdrivers can be used with the new switching EDU2AE/FR as well! This means they can benefit from all of the 2AE features (screw counting option, autoreverse, run time etc).



**ACE SCREW COUNTER  
(see page 14)**



**Model DOCK 01**



**SPIRAL CABLE**



**SOFT START AND SPEED  
REGULATION**

Model	Code	Features	Dimensions in	Weight lb	Screwdriver
EDU1FR	010010/FR	In: 90-260Vca Out: 18-30 Vcc power 120VA slow start and adjustable speed	5.4x4.6x2.6	1.3	FAB & RAF Series
EDU1FR/SG	010010/FR/SG	Input: start and reverse contacts Output: torque reached and lever signal	5.4x4.6x2.6	1.3	FAB & RAF Series
EDU2AE/FR	032000/FR	Run time, Additional signals, Serial Port, Optional screwdriver connector on back panel	7.7x6.7x4.3	5.3	PLUTO and FAB&RAF Series (see pages 5 and 12)

## BRUSHLESS Screwdrivers

TORQUE 0.4 TO 35.4 in/lbs

KBL series electric screwdrivers feature state-of-the-art brushless motors and clutch torque control, the perfect solution for clean room applications thanks to zero emissions of coal dust and other pollutants into the working environment. Small and lightweight for utmost operator comfort and with advanced ergonomic design, they ensure very low noise level, minimum vibrations and maximum safety (low supply voltage). Magnetic clutch switches last 10 times more than traditional switches: the absence of maintenance operations guarantees high productive continuity. KBL screwdrivers are equipped with a sophisticated electronic torque control system that will cut the power supply to the motor as soon as the pre-set torque has been reached. KBL drivers are available in inline body or for automation and they all come standard with an ESD-safe body. The new clutch for the adjustment of the tightening torque guarantees an excellent accuracy on the whole torque range. Rotation speed can be adjusted over a wide range: this function allows the operator to work on different materials always at the proper speed. They work with EDU1BL and EDU1FR control units (5 pin connector). It is also possible to connect two screwdrivers to one control unit via a double output connector (model DOCK02, or DOCK02/S for KBL with signals).

KBL../S are equipped with innovative electronics, which processes and sends torque, error and lever signals and receives remote start and reverse input. They're mainly indicated for automated applications (KBL..CA, see dedicated page).

They work with EDU1BL/SG control units (8 pin connector).

The new heavy duty cables and connectors, developed for robotic applications, are made of antistatic dissipative material for safe use in an EPA environment.



ANGLE HEAD

\* All models available in pistol type.

Inline KBL are also available in KBL..FR/AR, with autoreverse feature.

Model	Code	Torque in/lbs	RPM min-max	Weight lb	Dimensions in	Output	Control unit
KBL04FR	190004	0.4-3.5	650-1000	1.1	10x1.5	Hex 1/4"	EDU1FR or EDU1BL
KBL15FR	190015	3.5-13.3	650-1000	1.1	10x1.5	Hex 1/4"	EDU1FR or EDU1BL
KBL30FR	190030	6.2-26.6	650-1000	1.4	10.6x1.7	Hex 1/4"	EDU1FR or EDU1BL
KBL40FR	190040	8-35.4	450-750	1.4	10.6x1.7	Hex 1/4"	EDU1FR or EDU1BL
KBL04FR/S	190004/S	0.4-3.5	650-1000	1.1	10x1.5	Hex 1/4"	EDU1BL/SG
KBL15FR/S	190015/S	3.5-13.3	650-1000	1.1	10x1.5	Hex 1/4"	EDU1BL/SG
KBL30FR/S	190030/S	6.2-26.6	650-1000	1.4	10.6x1.7	Hex 1/4"	EDU1BL/SG
KBL40FR/S	190040/S	8-35.4	450-750	1.4	10.6x1.7	Hex 1/4"	EDU1BL/SG

## BRUSHLESS Control Units



**EDU1BL**



**EDU1BL/SG**  
Control unit with signals

All Kolver screwdrivers work in combination with a control unit acting as an AC to DC transformer and torque controller. The electronic control circuit cuts the power supply to the motor as soon as the pre-set torque has been reached. The EDU1BL, and EDU1BL/SG control units for KBL screwdrivers feature maintenance free state-of-the-art electronics with no wearing components. They come standard with the torque knob to adjust the torque (from 60% to 100%) of current control tools and a green LED which indicates when the control unit is on. EDU1BL/SG control unit works with KBL..FR/S or KBL..FR/CA and it additionally features signals for reached/not reached torque, pressed lever and remote start/reverse. A double output connector (Dock02 or Dock02/S for models with signals) is also available for operators using two screwdrivers at the same time. KBL..FR screwdrivers work in combination with our standard EDU1FR controllers. This option will allow existing customers to replace FAB & RAF drivers with no need to replace controllers.

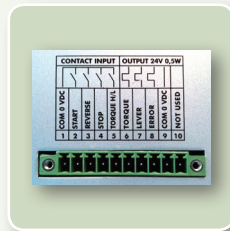

**BACK CONNECTOR**  
(EDU1BL/SG ONLY)



**ACE SCREW COUNTER**  
(see page 24)



**DOUBLE OUTPUT CONNECTOR FOR KBL**

A double output connector is available for operators using two KBL screwdrivers in the same working area. Model DOCK02 (code 020035) is meant to be used with KBL..FR, while model DOCK02/S (code 020035/S) is to be used with KBL..FR/S (with signals) or KBL..CA (for automation). The two screwdrivers can be used at the same time.

Model	Code	Features	Weight lb	Dimensions in	Screwdriver
EDU1BL	003000	Adjustable speed	1.3	5.4x4.6x2.6	KBL04FR, 15FR, 30FR, 40FR
EDU1BL/SG	003000/SG	Slow start and adjustable speed. Output signals: torque, error and lever; Input signals: start, stop and reverse.	1.3	5.4x4.6x2.6	KBL04FR/S, 15FR/S, 30FR/S, 40FR/S

## Angle Screwdrivers

Angle nutrunners are ideal for demanding applications where accessibility is a critical factor.

PLUTO Angle screwdrivers feature a fully electronic torque control system that guarantees highly accurate results. The light weight, very low noise level and the wide torque range make it a true alternative to pneumatic systems. PLUTO screwdrivers are to be used with EDU2AE units (see page 6). An angle screwdriver up to 266 in/lbs (available in CA version only) is available upon request.

KBL Angle screwdrivers combine all the advantages of brushless screwdrivers with the handiness of an angle headed tool.



Model	Code	Torque in/lbs	RPM min-max	Output	Dimensions in	Style	Control unit
PLUTO03ANG	130203/A	4.4-26.6	370-1300	Hex 1/4"	11.3x1.6	Inline ESD	EDU2AE Series
PLUTO3FR/ANG	131203/A	4.4-28.3	800-1300	Hex 1/4"	13.2x1.6	Inline ESD	EDU2AE Series
PLUTO5FR/ANG	131205/A	6.2-44.3	600-1000	Hex 1/4"	13.2x1.6	Inline ESD	EDU2AE Series
PLUTO06ANG	130206/A	7.5-53.1	200-850	Hex 1/4"	11.3x1.6	Inline ESD	EDU2AE Series
PLUTO7FR/ANG	131207/A	13.3-62	350-600	Hex 1/4"	13.2x1.6	Inline ESD	EDU2AE Series
PLUTO08ANG	130208	13.3-70.8	110-600	Hex 1/4"	11.3x1.6	Inline ESD	EDU2AE Series
PLUTO15ANG	130216/A	17.7-115	100-320	Sq 3/8"	11.9x1.6	Inline ESD	EDU2AE Series
PLUTO20ANG/SR	133220	26.6-159	60-200	Sq 3/8"	17.1x2.1	Aluminium body, start/reverse buttons	EDU2AE Series

Model	Code	Torque in/lbs	RPM min-max	Output	Dimensions in	Style	Control unit
KBL04FR/ANG	190004/A	0.4-3.5	650-1000	Hex 1/4"	12.4x1.5	Inline ESD	EDU1BL
KBL15FR/ANG	190015/A	3.5-13.3	650-1000	Hex 1/4"	12.4x1.5	Inline ESD	EDU1BL
KBL30FR/ANG	190030/A	6.2-26.6	650-1000	Hex 1/4"	13x1.7	Inline ESD	EDU1BL
KBL40FR/ANG	190040/A	8-35.4	450-750	Hex 1/4"	13x1.7	Inline ESD	EDU1BL





## Bit Guides for Screwdrivers

Bit Guides are the best accessory to help long bits, wire thread insert and riveters keep the correct perpendicular position. They can be installed on inline screwdrivers model PLUTO3, PLUTO6, PLUTO10, PLUTO15 and on any inline KBL:

- RIV HD1, 0.3in hole (code 010180) for PLUTO3D, PLUTO6D, PLUTO10D/N, PLUTO15D/N
- RIV HD2, 0.3in hole (code 010181) for KBL30FR and KBL40FR, also for models with signals (KBL..FR/S) and autoreverse (KBL..FR/AR)
- RIV HD3, 0.1in hole (code 010182) for PLUTO3D, PLUTO6D, PLUTO10D/N, PLUTO15D/N
- RIV HD4, 0.1in hole (code 010183) for KBL04FR and KBL15FR, also for models with signals (KBL..FR/S) and autoreverse (KBL..FR/AR)
- RIV HD5, 0.1in hole (code 010184) for KBL30FR and KBL40FR, also for models with signals (KBL..FR/S) and autoreverse (KBL..FR/AR)

Riveters and wire thread inserts may require the screwdriver to automatically start a loosening operation once the torque has been reached. This is easily achieved via the "autoreverse" feature, which is available either on PLUTO drivers (by selecting the proper settings on the EDU2AE control unit) and brushless screwdrivers, specifically models KBL..FR/AR (see page 14).

RIV HD bit guides are supplied standard with 0.1 in hole or 0.3 in hole with roller bearings (special dimensions can be made upon request).

## A C C S E R I E S

### ACC Screwdrivers

ACC screwdrivers with shut off torque control through mechanical clutch are direct plug-in tools with built-in PCB for automatic cut off and AC to DC rectifier. They are ideal for applications where portability is needed to minimize costly set-up time. ACC models have the unique feature of selectable push to start or push and lever start.

To select the working mode just slide the switch located by the start lever.



REVERSE SWITCH

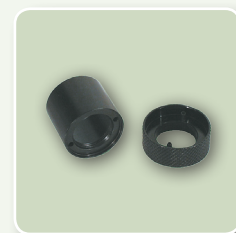

TORQUE ADJUSTING NUT COVER

Model	Code	Torque in/lbs	RPM max	Weight lb	Dimensions in	Controller
ACC2210	141910/110	1.8-8.9	950	1.7	10x1.4	120 VAC
ACC2220	141920/110	6.2-17.7	950	1.8	10x1.4	120 VAC
ACC2222	151222/110	8-17.7	2400	1.9	10.4x1.5	120 VAC
ACC2230	151930/110	8.9-26.6	950	1.9	10.4x1.5	120 VAC
ACC2245	151945/110	8.9-39.8	450	1.9	10.4x1.5	120 VAC

Optional Lock-out Cover & Nut Assembly available for all ACC models (code 219011).

## Torque Testers – K Series



The K Series is a totally new class of analysers. They feature a built-in transducer and also have the unique ability to connect to an external transducer. Using a high performance circuitry they collect, store and eventually download torque measures for a complete analysis of the tool and/or the joint. Priced at a low level, this tester has become popular among those companies wishing to improve their product quality through the precise control of torque.

- User friendly menu.
- Accuracy: +/- 0.5% of the displayed value.
- Internal transducer for tests on a joint simulator (supplied with the unit).
- Connection for external transducer (transducer not included).
- 500 readings memory.
- Selection among Nm, Ncm, Kg.cm, in/lbs.
- RS232C output (cable not included).
- Indication <=> of the preset values.
- Output signal at preset reached value.
- Clockwise and counter-clockwise measurement.
- 3 models of operation: Peak +, Peak -, Track.
- Manual or automatic reset.
- 9 V rechargeable battery provide 4 hours of continuous operation. Automatic switch off to reduce battery consumption.
- 125% transducer overload protection.
- English and Italian menu.

Supplied in a plastic carrying case, with one rechargeable battery, 1 joint simulator (semielastic), instructions manual and certificate of calibration. Additional joint simulators (rundown adapters) for hard joint or fully elastic joint available on request.



JOINT SIMULATOR



EXTERNAL ROTARY  
TRANSDUCER



EXTERNAL ROTARY  
TRANSDUCER



KEYPAD

Model	Code	Torque in/lbs	Dimensions in	Weight lb
K1	020402	0.4-8.9	6.8x5.6x1.6	2.2
K5	020403	2.7-44.3	6.8x5.6x1.6	2.2
K20	020404	4.4-177	6.8x5.6x1.6	2.2
KTE5	022405	4.4-44.3	External transducer for K5	
KTE25	022425	17.7-221.3	External transducer for K20	



Controlling torque is vital for companies to ensure their product's quality. Fasteners that are insufficiently torqued can vibrate loose and excessive torque can strip threaded fasteners. Using a quality torque analyzer has become increasingly important for many companies to ensure that proper torque is being applied.

**TORQUE TESTER - Mini K/S Series**

MINI K/S Torque Testers feature a built-in transducer. The easy-to-use torque tester is ideal for checking all power tools up to 177 in/lbs. The small size and portability of the MINI K/S makes it ideal for checking torque tools on the production floor regularly to ensure the tools are always calibrated.

- Built-in transducer.
- Three models with 8.9 in/lbs, 44.3 in/lbs and 177 in/lbs max torque.
- Three units of torque measurement available; Nm, Kg.cm, in/lbs.
- Four digit display.
- Manual and auto reset functions to clear displayed values.
- Battery powered (9V) and AC adapter. 9V battery provides 30 hours of continuous operation.
- RS232C serial port with date and hour
- Automatic shut down to extend battery life.
- Torque Tester includes a spring washers joint simulator (miniK5/S and miniK20/S) or built in joint simulator (miniK1/S) and a case.

Accuracy: 0.5% of reading from 10% to 100%.  
Accuracy: 1% of reading from 1% to 10%.

**TORQUE TESTER - Mini Ke/S series**

The Mini Ke/S system consists of a torque readout and an external rotary transducer. The Rotary Torque Transducer is the ideal torque-auditing tool for testing the actual torque being applied on the assembly application. By connecting a rotary torque transducer between an electric or pneumatic tool and an assembly application, you can monitor the real torque being applied from the tool to fastener or bolt.

Accuracy: 0.5% of reading from 10% to 100%.  
Accuracy: 1% of reading from 1% to 10%.

Correction factor (FATC): it is possible to connect different transducers to the same torque reader. The new Kolver Torque Analyser software for Mini K/S and Mini Ke/S Torque Testers features real-time tracking of each measurement and calculation of CM and CMK. A Real-time chart for each torque measurement is displayed on your PC screen (when "track mode" on the tester is enabled). The chart will show the trend of the single screwing operation or, in case of multiple screwing operations it will show the results according to the settings on the torque tester and software (for example if you're keeping track of multiple operations at max torque, the chart will show the trend of these max torques). You can also export an Excel file (max 30 measurements) with corresponding CM-CMK values: this is useful for testing the torque accuracy of the screwdriver.

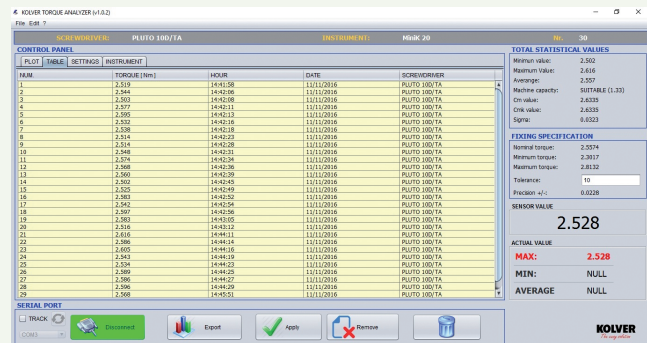
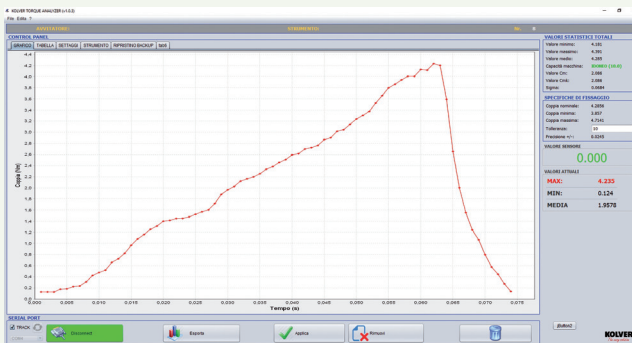

Model	Code	Torque in/lbs	Features	Dimensions in	Rotary Transducer Dimensions in	Weight lb
mini K1 / S	021402/S	0.4-8.9	With built-in joint simulator, serial port and 'Torque Analyzer' software for PC	5.9x2.8x1.8	-	1.8
mini K5 / S	021403/S	2.7-44.3	With joint simulator, serial port and 'Torque Analyzer' software for PC	5.9x2.8x1.8	-	1.8
mini K20 / S	021404/S	4.4-177	With joint simulator, serial port and 'Torque Analyzer' software for PC	5.9x2.8x1.8	-	1.8
mini KE 5 / S	021405/5/S	4.4-44.3	With external transducer, serial port and 'Torque Analyzer' software for PC	5.9x2.8x1.8	1x3.6	1.1 (without transducer)
mini KE 25 / S	021405/25/S	17.7-221.3	With external transducer, serial port and 'Torque Analyzer' software for PC	5.9x2.8x1.8	1x3.6	1.1 (without transducer)
mini Ke 50 / S	021405/50/S	Up to 442 in/lbs	With external transducer, serial port and 'Torque Analyzer' software for PC	5.9x2.8x1.8	3.5x2x2.5	1.1 (without transducer)



## Folding and Linear Torque Reaction Arm Series

Linear arms manoeuvre smoothly as they absorb the torque reactions from the screwdrivers providing ergonomic support for the operator. The fluid movement increases precision and production for a variety of torque applications. Linear arms keep the tool perpendicular and prevent cross threading and side load. They reduce RMI (Repetitive Motion Injury) and CTS (Carpal Tunnel Syndrome) while boosting production. Each model extends in horizontal direction and arm length is adjustable.

A diameter reduction adapter (code 234545) is available for our PLUTO35 and PLUTO50 screwdriver (Ø 2.24 in).

Torque reaction arm PA2KOL, code 010600, has been designed to eliminate the reaction generated by screwdrivers when they stop at the pre-set torque. Options include table or wall mount.

Model	Code	Max Torque in/lbs	Min Reach in	Max Reach in
PA2KOL	010600	177	17.3	25.2
LINAR1	010681	221	7.2	26.2
LINAR2	010682	442	7.2	26.2
LINART	010683	221	4.5	29.1

## TELESCOPIC TORQUE REACTION ARMS

### Telescopic Arm Series

CAR series torque reaction arms are designed to eliminate the reaction that screwdrivers generate when they stop at the preset torque (up to 442 in/lbs). Their carbon structure makes them extremely lightweight and incredibly resistant at the same time. This means that they resist degradation in high fatigue applications much better than conventional materials. A diameter reduction adapter (code 234545) is available for our PLUTO35 and PLUTO50 screwdriver (Ø 2.24 in).

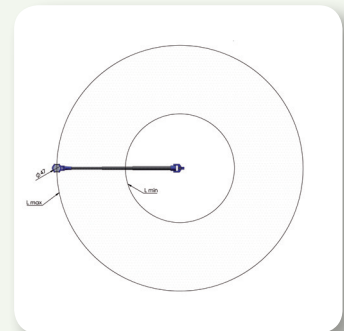
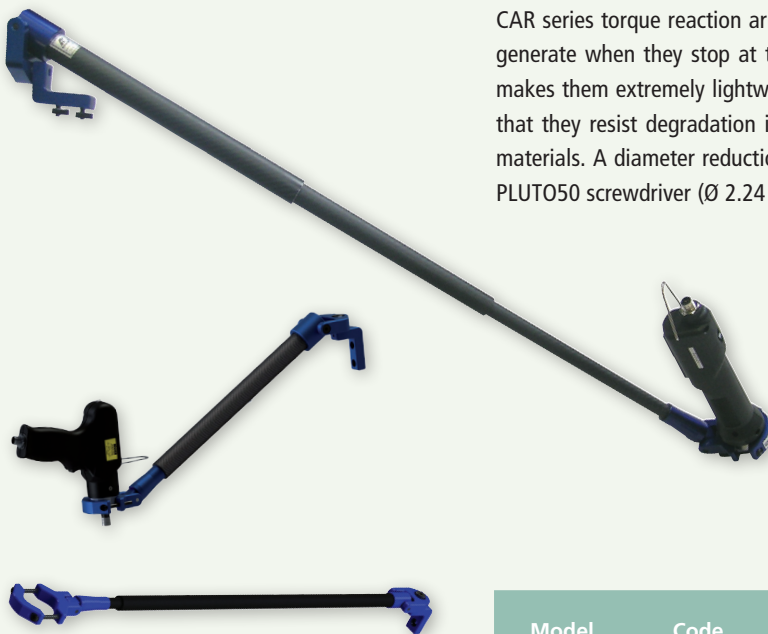

Model	Code	Min Reach (L min) in *	Max Reach (L max) in *	Weight lb	Max Torque in/lbs
CAR101	010661	21.6	35.7	0.55	89
CAR281	010663	19.3	37.4	1.30	221
CAR282	010664	28.7	65.0	1.65	221
CAR501	010665	19.3	37.4	1.40	442
CAR502	010666	28.7	65.0	1.80	442

\* Measured with clamp Ø 1.9 in

## Suspended Torque Arm Series

The new Suspended Torque Arms are the ideal solution to increase productivity. They can be easily installed on most workplaces to help the operator handle the screwdriver in total safety and stability:

- With minimized reaction force you will also improve finished product quality because there is no movement of the tool and all torque is absorbed in the joint.
- Improve the comfort of the operator and the productivity clearing the work area.

Three models available, depending on the motion of the axes:

- SAR15 Z -> Z Axis
- SAR15 XZ 85 -> XZ Axes
- SAR15 XYZ 855 -> XYZ Axes

The new arms are supplied without tool holder - to be purchased depending on the screwdriver:

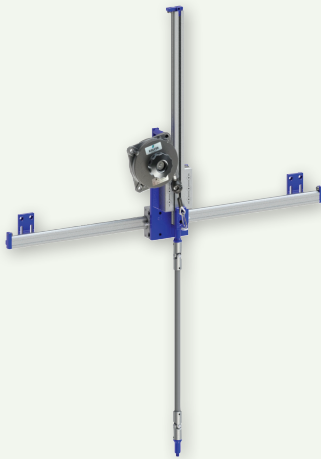
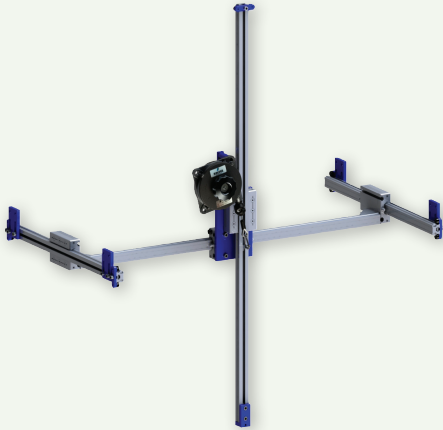

*TOOL HOLDER FOR PLUTO  
INLINE*



*TOOL HOLDER FOR PLUTO  
WITH ANGLE HEAD*



*UNIVERSAL TOOL HOLDER  
FOR ANY SCREWDRIVER*

Model	Code	Vertical Stroke "Z" (in)	Horizontal Stroke "X" (in)	Lateral Stroke "Y" (in)	Max Torque in/lbs
SAR15 Z	010690/Z/5	14.3	/	/	133
SAR15 XZ 85	010690/XZ/85	14.3	27.2	/	133
SAR15 XYZ 855	010690/XYZ/855	34.8	27.2	14.8	133
Tool holder for PLUTO inline		010695	For any PLUTO..D, PLUTO..FR, PLUTO..D/TA e RAF..NS/FR		
Tool holder for PLUTO w/angle head		010695/P	For any PLUTO..ANG		
Universal Tool Holder		010695/UNI	For any screwdriver (max diameter 1.9 in)		

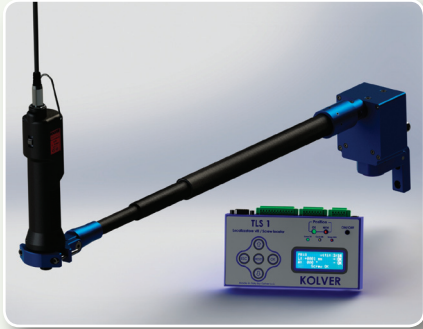

TLS1/CAR

## TLS1 Positioning Arm

The TLS1 Arm is an “intelligent” system that error-proofs your assembly ensuring that every screw is in the correct location at the right torque. Assembly sequences and X-Y coordinates are easily programmed with user interface screens through the keypad from the intuitive menu. Torque programs are automatically selected and enabled from the screwdriver controller based on the TLS1 Arm locations and current sequence step. No PC is required. A fixture to hold your work in the same place every time is highly recommended.

The TLS1/CAR Arm consists of a torque reaction arm with an encoder mounted at the pivot point and with a linear metering resistor. The encoder records the angle and the linear resistor records the distance. The TLS1 Control Box converts the angle counts of the encoder and the distance detected by the resistor to the precise X-Y position of the screwdriver. X-Y accuracy can be set by the operator according to each application.

TLS1 arm includes cable for EDU1FR/SG (code 260003/1) or EDU2AE and EDU1BL/SG (code 260004/1) controllers.

### Main features:

- 8 available programs.
- Up to 35 screws per program.
- Screw position (length/angle).
- Programmable tolerance.
- Statistics.
- Manual reset.
- Password protected.
- Units of measurement (mm, in).
- Language option.
- Accuracy: length  $\pm 0.04$  in; angle  $\pm 1^\circ$ .
- External keyboard and serial port for easy programming and reporting.



TLS1 BOX

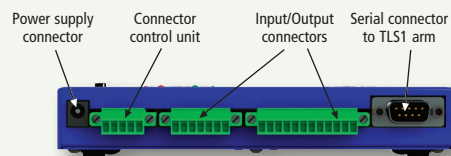



TLS1/LINAR1

### TLS1 with Linear Arm

The new error proof positioning arms TLS1/LINAR1 and TLS1/LINAR2 work just like LINAR1 and LINAR2 with the addition of positioning sensors a real time feedback on the position of the arm, which is very useful for default calibrations. Max torque and reach are the same as LINAR1 and LINAR2 respectively.

Adapter code 234545 is required for screwdriver model PLUTO35 and PLUTO50.



TLS1/LINART

### TLS1 with Folding Arm

The new error proof positioning arm TLS1/LINART features a folding arm for extreme flexibility and accuracy. Thanks to the positioning sensors you can have a real time feedback on the position of the arm, which is very useful for default calibrations. Max torque and reach are the same as LINART.

Adapter code 234545 is required for screwdriver model PLUTO35 and PLUTO50.

All TLS1 arms are supplied standard with TLS1 Unit version 2.00, which adds new features to the existing software and provides different minimum distances between screws at maximum arm reach (see chart below).

Model	Code	Max Torque in/lbs	Dimensions in Min	Dimensions in Max	Min distance between screws at the max arm extension
TLS1/CAR281	010663/TLS1	221	19.7	37.4	0.35 in
TLS1/CAR282	010664/TLS1	221	29.5	65.7	0.59 in
TLS1/CAR501	010665/TLS1	442	19.7	37.4	0.35 in
TLS1/CAR502	010666/TLS1	442	29.5	65.7	0.59 in
TLS1/LINAR1	010681/TLS1	221	10.7	25.7	0.24 in
TLS1/LINAR2	010682/TLS1	442	10.7	25.7	0.24 in
TLS1/LINART	010683/TLS1	221	4.5	29.1	0.28 in

To be used with:

260004/1 Cable TLS1 for EDU2AE + EDU2AE/TOP + EDU1BL/SG

260003/1 Cable TLS1 for EDU1FR/SG

## ACE Screw Counter



The ACE screw counter is a process control system that monitors the fastening assembly process. It tracks, in real time, the fastening of each screw in an assembly, then notifies the result. It keeps a summary of good and complete assemblies as well as of bad and incomplete ones throughout the production day. The ACE is easily programmed with user interface screens through the keypad. Walk through a few simple steps to input the parameters for total number of fasteners required in a completed assembly and the fastening process can begin. The unit gives the operator audible and visual indications that the assembly has been completed without error and it is safe to move on to the next process step or if it has been rejected.

Main features:

- ACE includes the screw counter + cable for connection to the control unit.
- To be connected to EDU1BL/SG (code 020022), or EDU1FR/SG (code 020021).
- 8 independent programs.
- Up to 99 screws for each program.
- Sequence of 4 programs.
- Min and max fastening time (accuracy: 0.01 sec).
- Separate displays for parameters setting and fasteners count.
- OK, End Cycle and Error lights.
- Statistics: Total number of correct screws done, wrong screws, cycles done, sequences done.
- I/O signals.
- Password protected.
- Wall mountable.
- Remote control of the system (optional).
- RS232 port.

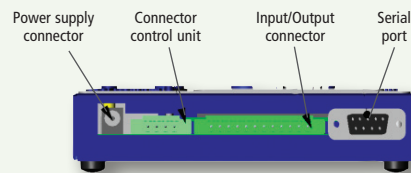
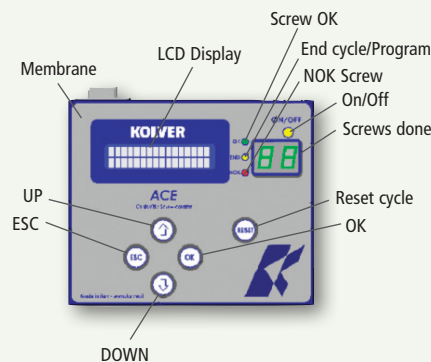

Code	Model	Dimensions in	Weight lb	Control unit
020021	ACE	5.4x5.2x1.2	1.2	EDU1FR/SG
020022	ACE	5.4x5.2x1.2	1.2	EDU1BL/SG



## NFK Series Screwfeeders



NFK Nxx

The new Kolver feeders, model NFK-Nxx (xx stands for the screw size) are supplied with interchangeable spacers between the rails (spacer size: 0.05 in to 0.20 in). You can also combine spacers to reach the desired rail width. Dimensional drawings and complete up-to-date info available on our website.

The new NFK UNI can be used with any (non-countersunk) screw with diameter 0.06–0.2 in. NFK..RS delivers one screw at a time to a specific position so that one single screw can be easily picked up when using an autocatcher or suction head. A trimmer on the side panel allows to adjust how fast each screw is supplied. Available for screws with shank diameter from 0.05 in up to 0.20 in.

The whole NKF Screw Feeder Series can handle max. 0.8 in long screws.

An optional cover is available in order to avoid screws falling inside the NFK..RS screw feeder.



NFK..RS

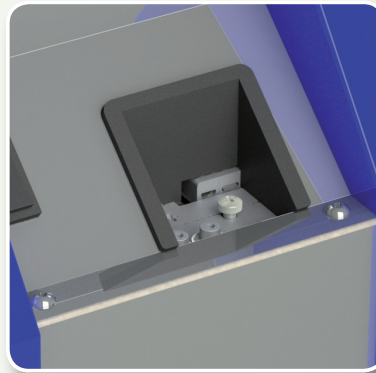

Optional cover NFK..RS

Model	Code	Max shank Ø in
NFK UNI	014705	0.06-0.20
NFK N14	014514	0.06
NFK N17	014517	0.07
NFK N20	014520	0.08
NFK N23	014523	0.09
NFK N26	014526	0.10
NFK N30	014530	0.12
NFK N40	014540	0.16
NFK N50	014550	0.20

Model	Code	Max shank Ø in
NFK N12/RS	014512/RS	0.05
NFK N14/RS	014514/RS	0.06
NFK N17/RS	014517/RS	0.07
NFK N20/RS	014520/RS	0.08
NFK N23/RS	014523/RS	0.09
NFK N26/RS	014526/RS	0.10
NFK N30/RS	014530/RS	0.12
NFK N40/RS	014540/RS	0.16
NFK N50/RS	014550/RS	0.20

Here below you can find a complete list of accessories for Kolver screwdrivers and control units.



Model	Code	Features
16.4 ft 5 pin cable	200563	This cable is available upon request for any screwdriver with 5 pin connector. Length: 16.4 ft.
16.4 ft 8 pin cable	250563/N	This cable is available upon request for any screwdriver with 8 pin connector. Length: 16.4 ft.
Cable with strain relief	250063/H	The cable with spring is more resistant thanks to a longer connector and spring, which makes the cable up to 4 times more durable. Perfectly compatible with any 5 pin (code 200063/H) or 8 pin (code 250063/H) screwdriver/control unit.
Tool balancer TECBA1	010300	Tool balancers TECBA1 allow screwdrivers to be positioned over the work station for comfortable operation. Models with higher capacity available on request.
ARMPV1 support arm	010500	ARMPV1 support arm consists of a vertical support on which a 180° pivoting arm is attached.
Double output connector DOCK01	020020	A double output connector is available for operators using two FAB or RAF screwdrivers in the same working area. One end is to be connected to the controller (cable included), the other end to the drivers. Screwdrivers not to be used at the same time
Double output connector DOCK02	020035	A double output connector is available for operators using two KBL..FR (not KBL..FR/CA nor KBL..FR/S) screwdrivers in the same working area. The screwdrivers can be used at the same time.
Double output connector DOCK02/S	020035/S	A double output connector is available for operators using two KBL..FR/S screwdrivers in the same working area. The screwdrivers can be used at the same time.
Double output connector DOCK04	020045	A double output connector is available for operators using two PLUTO screwdrivers with EDU2AE/ TOP in the same working area. The screwdrivers cannot be used at the same time.
Double output connector DOCK04/TA	020045/TA	A double output connector is available for operators using two PLUTO screwdrivers with EDU2AE/ TOP/TA in the same working area. The screwdrivers cannot be used at the same time.
Diameter Reduction Adapter for PLUTO35 and PLUTO50	234545	A diameter reduction adapter is to be attached to our PLUTO35 and PLUTO50 screwdrivers (ØD 2.2 in) in case of use with our reaction arms.
Angle Head FAB - ANG HD1	010100	When space is limited a right angle head can be easily attached to lever start FAB screwdrivers. ANG HD1 is the cost effective alternative to ANG HD8. 1/4" hex - max torque 53 in/lbs
Angle Head RAF - ANG HD2	010120	When space is limited a right angle head can be easily attached to lever start RAF screwdrivers. ANG HD2 is the cost effective alternative to ANG HD9. 1/4" hex - max torque 53 in/lbs
Angle Head FAB - ANG HD8	010143	When space is limited a right angle head can be easily attached to lever start FAB screwdrivers. Model ANGH8 is suitable to FAB series. 1/4" hex - max torque 53 in/lbs
Angle head RAF - ANG HD9	010144	When space is limited a right angle head can be easily attached to lever start RAF screwdrivers. Model ANGH9 is suitable to RAF series. 1/4" hex - max torque 53 in/lbs
Socket tray for TOP unit	020042	When using a multiple torque system a socket tray can be a useful accessory for program selection. It's very easy to use: the control unit automatically selects the correct preset program when a bit or socket is removed.
Switchbox for TOP unit	020033	A switch box can be a useful accessory for multiprogram selection. It's very easy to use: each time a button is pushed, the control unit automatically selects the preset program.
KBL clutch cover	02002-02002-/CA	Clutch cover for KBL. Code 020028 for KBL04-15FR; Code 020028/CA for KBL04-15FR/CA; Cod. 020029 for KBL30FR; Code 020029/CA for KBL30FR/CA.

Here below you can find a complete list of accessories for Kolver screwdrivers and control units.



Model	Code	Features
Telescopic Spindle 1/4" - 1/4" max 62 in/lbs	800322	The Telescopic Spindle (axial compensator) is used in multi spindle applications to balance the screw tightening process and compensate depth difference across multiple fasteners. For PLUTO..FR/FN, MITO../FN, KBL../FN.
Telescopic Spindle 1/2" - 1/2" max 442 in/lbs	800319	The Telescopic Spindle (axial compensator) is used in multi spindle applications to balance the screw tightening process and compensate depth difference across multiple fasteners. For PLUTO..50/FN.
Telescopic Spindle 1/4" - 3/8" max 133 in/lbs	800320	The Telescopic Spindle (axial compensator) is used in multi spindle applications to balance the screw tightening process and compensate depth difference across multiple fasteners. For PLUTO3-6-10-15.
Telescopic Spindle 3/8" - 3/8" max 310 in/lbs	800321	The Telescopic Spindle (axial compensator) is used in multi spindle applications to balance the screw tightening process and compensate depth difference across multiple fasteners. PLUTO20-35.
Coloured Rings	2000--	Coloured rings are useful to distinguish and identify different screwdrivers at a glance. Available in different colours: Code 200085 - Blue Code 200086 - Red Code 200087 - Yellow Code 200088 - Green Code 200089 - Black
Barcode reader BRRCR90	020050	The BRRCR90 barcode reader allows the operator to instantly select the program previously set on the control unit. To be used with EDU2AE/TOP or EDU2AE/TOP/TA.
Serial Printer PRNTR1	020026	The PRNTR1 serial printer gives the possibility to instantly print the results of each tightened screw. It works with EDU2AE/TOP, EDU2AE/TOP/TA, EDU2AE/HPRO control units and K and Mini K../S torque testers.
Ethernet Device	020075	Kolver Ethernet Device makes it possible to connect a PC to any EDU 2AE/TOP - TOP/E - TOP/TA via remote LAN connection.
Light stack	020080	The light stack allows better visibility of output signals. Made for any control unit with signals. Supplied standard with 8.2 ft cable and 10pin connector for CN1 (EDU2AE - EDU2AE/TOP). Wiring for other Kolver control units available on request.
Start / Reverse Pedals	020070	Start and reverse signals can now be activated using our new foot pedal. Supplied standard with 11 ft cable and connector for any EDU2AE and EDU2AE/TOP unit.
Autocatcher	01011-	An Autocatcher allows the operator to pick up and fasten stainless steel, brass, copper and plastic screws by using one hand! Sizes available: AC1.47 for M1 to M1.7, code 010115, AC2.3 for M2 to M3, code 010113, AC3.5 for M3 to M5, code 010114.
A2 and A3 Suction Heads	010111/-	A suction head is the best way to handle non-magnetic screws (stainless steel, brass, plastic etc.). Available in two models: A2 for M2-M2,6 screws (code 010111/1) and A3 for M3-M4 screws (code 010111/2). Both models can be installed on any screwdriver.
ASP HD Suction Heads	0101--	A suction head is the best way to handle non-magnetic screws (stainless steel, brass, plastic etc.). ASP HD heads are available for NATO15 (model ASP HD6 - code 010117), NATO50 (model ASP HD7 - code 010118), MITO15 (model ASP HD8 - code 010119) and PLUTO3-15 (model ASP HD9 - code 010121).



## OUR COMPANY

Founded in 1989, KOLVER has soon taken the leadership in the European market of precision electric screwdrivers for industry. Thousands of state-of-the-art drivers are produced every year in Italy and then shipped to more than 30 countries worldwide.



ISO 9001 certified since 1998, KOLVER has gained international recognition for building premier quality innovative products that meet or even anticipate the most rigorous customer requirements.

The Kolver family of tools is one of the most comprehensive in the electric power tool industry covering a wide range of torque at several speeds, suitable for an indefinite number of applications. Kolver tools feature either shut off clutch or current control system, coreless or brushless motors all controlled by a state-of-the-art electronic control unit.

Thanks to their low installation, operating and maintenance costs as well as to their reduced vibration and noise level, Kolver electric screwdrivers represent the perfect alternative to pneumatic screwdrivers for screws up to M10.

### ONE YEAR LIMITED WARRANTY

KOLVER products are guaranteed against defective workmanship or materials, for a maximum period of 12 months following the date of purchase from KOLVER, provided that its usage is limited to single shift operation throughout that period. If the usage rate exceeds that of single shift operation, the guarantee period shall be reduced on a prorata basis. If, during the guarantee period, the product appears to be defective in workmanship or materials, it should be returned to KOLVER or its distributors, transport prepaid, together with a short description of the alleged defect. KOLVER shall, at its sole discretion, arrange to repair or replace free of charge such items. This guarantee does not cover repair or replacement required as a consequence of products which have been abused, misused or modified, or which have been repaired using not original KOLVER spare parts or by not authorized service personnel. KOLVER accepts no claim for labour or other expenditure made upon defective products. Any direct, incidental or consequential damages whatsoever arising from any defect are expressly excluded. This guarantee replaces all other guarantees, or conditions, expressed or implied, regarding the quality, the marketability or the fitness for any particular purpose. No one, whether an agent, servant or employee of KOLVER, is authorized to add to or modify the terms of this limited guarantee in any way. However it's possible to extend the warranty with an extra cost.



## KOLVER SCREWDRIVER IS...

- **ERGONOMIC**  
Advanced grip design, light in weight, vibrations within the norms, for maximum operator comfort
- **CLEAN**  
No air exhaust + No lubrication = a cleaner environment
- **SAFE**  
The tool works below 50 V
- **FLEXIBLE**  
From the controller you can adjust the running speed and the slow start duration. Multi torque models also available for additional functions
- **ACCURATE**  
With the electronic shut off mechanism the accuracy is better than  $\pm 5\%$  of the pre-set value
- **FOR EVERY APPLICATION**  
Range up to 442 in/lbs, straight, pistol, 90°, ESD, with vacuum, lever start or push to start...
- **NOISELESS**  
Noise within 55 dB(A)
- **COST EFFECTIVE**  
Low purchasing price + virtually no maintenance + no need of compressed air line + no need of spiral hoses & couplers & filters & regulators-lubricators = operating cost up to 200 times cheaper than pneumatic screwdrivers.